

Autocue

Q Series

The QSeries Product Family:
Newsroom, Production, Automation and Media Management
Software

Product Description and General Information

January 2009

Version 2.0

Prepared by Neil Hutchins

Autocue Group Ltd.
Unit 3, Puma Trade Park
145 Morden Road
Mitcham
Surrey
CR4 4DG
UK

Tel: +44 (0)20 8665 2992
Fax: +44 (0)20 8687 4869
E-Mail: neil.hutchins@autocue.co.uk
Web: www.autocue.com

QSeries Product Description and General Information

Table of Contents

- 1. Company Profile 3
- 2. QSeries Overview 4
 - 2.1 Underlying Philosophy 4
 - 2.2 QSeries Automation Overview 4
 - 2.3 System Structure 5
- 3. Workflow Information 9
 - 3.1 Newsroom Workflow 9
 - 3.2 Media Handling18
 - 3.3 Playout26

1. COMPANY PROFILE

Autocue (n. propr) a device, unseen by the audience, displaying a television script to a speaker or performer as an aid to memory
The Concise Oxford Dictionary

Autocue n Trademark electronic television device for displaying speaker's script unseen by audience
Collins Gem Dictionary

Autocue is the generic term for television prompting. High-profile presenters and performers rely on the product for eye contact with the camera and, through their frequent on-air references to 'the autocue', the company's name became part of the English language.

Autocue Ltd. was registered as a company in 1955, and at the same time patented the first prompter to be used in Europe. The synchronised electric paper roller prompter, with one inch jumbo type, used a mirror and a piece of semi-reflective glass to focus the image of the moving text over the lens of the camera into the presenter's eyeline. The early 1970's saw the introduction of Autocue's closed-circuit prompters, and the company's reputation continued to grow with its association with programmes such as BBC News, The Two Ronnies, Nationwide, Match of the Day, Braden's Weeks, The Frost Programme, Parkinson, This is Your Life and Opportunity Knocks, to name but a few. Today, Autocue and QTV, its sister company in America, have probably sold to every country in the world and have a very large proportion of all prompting hardware sales worldwide. Handling thousands of productions each year, the company provides a 24-hour service to meet the high standards required by broadcasters such as the BBC.

Over the last twenty years, the company has also focused on scripting and newsroom systems as a logical extension to prompter sales and hire. The Autocue 2000 was the first multiuser prompting system, used successfully in several television newsrooms. It was followed in the late 1980's by ScriptNet, which was one of the first networked scripting systems and provided some unique script layout facilities. During the 1990's Autocue was the major world distributor for the NewsMaker Electronic Newsroom, covering everywhere except for the Americas, with successful markets in the UK, Europe, Africa, Australia and Asia.

Since 1996, Autocue has concentrated on the QSeries product range – state-of-the-art scripting, newsroom and automation software written in-house by Autocue's own programmers. The QSeries is innovative and utilises advanced technology, but at the same time is affordable, open, reliable, scalable and easy to implement. With hundreds of sites and thousands of users worldwide, it is an established, proven product.

Autocue Group Ltd. now consists of three companies: QTV Inc. in New York, handling prompting in the Americas, Autocue Systems Inc. in North Carolina, handling part of the worldwide technical support operation and Autocue in the UK, covering the rest of the world.

Although sometimes referred to as the 'Cinderella' of the broadcasting industry, Autocue has always understood the old adage "The show must go on". This attitude is reinforced today with 24-hour 365-day support arrangements and a willingness to do whatever necessary to keep the programme on-air.

2. QSERIES OVERVIEW

The QSeries system is comprised of four main integrated modules. Depending on the exact requirements, one or more of these components:

- **QSeries Network Client** is a multi-user production scripting system.
- **QNews** is a multi-user *newsroom* computer system – NRCS
- **QTX** provides integrated, multi-channel Master Control automation.
- **QMedia** provides media acquisition, editing and play out.

QSeries is a client/server application, and each module consists of one or more 'back-end' QSeries Servers and (in most cases) one or more 'front-end' QSeries Clients.

QSeries software has been designed to fulfil many functions. It is a networked newsroom system. It is a multi-user prompting system. It is a broadcast automation system. It is a script production system. It serves in any and all of those roles, and provides a host of other features as well. Each aspect of its operation has been designed and implemented to operate in the best possible way and the whole product has been engineered to provide a completely integrated solution.

2.1 Underlying Philosophy

The QSeries has been designed with a number of fundamental issues in mind;

- 1) Integrated Software Suite: to provide a complete news and automation solution without reliance on third-party software.
- 2) Multi-lingual: allowing almost any language to be used throughout the product.
- 3) Comprehensive Editing Facilities: a flexible script editor suitable for applications from news to drama, with true multicolumn facilities.
- 4) Reliable: sharing critical data over several standard servers to provide load balancing and data mirroring.
- 5) Scalable: any number of workstations connected with standard networking equipment.
- 6) Active Updating: to ensure that everybody sees the correct, current information.
- 7) Easy to use: a simple Windows-style approach, which can be customised as much or as little as necessary, and a GUI that empowers not constrains.

2.2 QSeries Automation Overview

The term 'automation' is broad, and covers a variety of functions. Historically, specific software packages have been used to manage different automation applications, and have frequently relied on other systems to provide the schedule information. The QSeries has been designed to incorporate scheduling and control functions into one integrated application and to handle different types of automation requirements.

The most common use of automation is to provide some level of device automation at transmission time, based upon information within a specified running order. QSeries provides two types of transmission control – discrete and continuous. Discrete transmission control (referred to as News Automation) will often be used during live programmes, allowing studio links to be interspersed with recorded packages and simplifying control of devices such as character generators and still stores. This style of operation relies on human intervention, to start video playing or to fade in a caption, for instance. Continuous transmission control (or Transmission Automation) provides a flexible, automatic way to manage programme output which is entirely, or mostly, pre-recorded. This type of control provides similar features to News Automation, in terms of the

devices it can manage and the way in which it can operate, but can deal with events at a programme level rather than just an item level. For instance, News Automation would be able to load and cue the five video clips and prepare the three captions that relate to a particular item, but it would not have any concept about how that item fits into the overall running order. Transmission Automation, by contrast, would be able to recognise that the item is the last in the show, for example, and then take particular actions to finish show transmission correctly. However, it must be stressed that although there are two different 'modes' of automation control, there is a great deal of overlap in the way that QSeries handles the processes and the operator is free to switch from one to another almost at will.

2.3 System Structure

The two diagrams below illustrate a generic QSeries system shown as a number of functional blocks and a more detailed network diagram that is specific to this proposal.

The QSeries system is a modular application constructed from a number of server and client components which are installed according to individual customer requirement.

The most important part of any QSeries system is the **DBServer** – in this example running on a cluster of two PCs. The DBServer stores, and provides access to, all schedule and run order information. QSeries Clustering is a proprietary method of providing system redundancy using standard PC hardware. The core DBServer software can be distributed over two or more computers, ensuring that individual hardware failures do not affect the network as a whole. Clustering ensures that all DBServer data is mirrored between primary and secondary servers, and the overall load is balanced by distributing primary and secondary responsibility between servers in the cluster. The process is completely automatic and invisible to the users. If the primary server for the particular queue that a user is working in fails, the WinCue client software automatically switches to the secondary server for that queue, without interrupt to the user. Clustering requires additional, matching PCs with a dedicated local network between them.

The **Archive Server** stores and indexes all script archives, and is discussed in more detail in the Section 3.1.2 below.

The Wire Server can handle incoming serial feeds from up to twelve different News Agencies or data services. The wire server software provides a number of features, including;

- long term storage of incoming stories
- searching and sorting of stored stories
- distribution of individual stories by category or content
- real-time indexing of incoming stories to provide fast search facilities
- notification of story receipt to individual or groups

The **Media Server** carries out all automatic processes relating to media handling, including scheduled recording, scavenging and low-res conform.

The **Low-Res Server** stores all low-resolution material and controls all low-res acquisition operations.

One or more **Device Control Interface (DCI) Servers** sit between the third-party devices and the rest of the QSeries system. Most controlled devices, including the video servers, tape machines, caption generators, transmission switches, timecode readers, etc. would be connected to a DCI Server, either directly via a serial connection, or indirectly via an IP network connection. QSeries system modules gain access to a particular hardware resource across the network and through the DCI Server at a high level, without having to know low-level instructions for the specific device in use. A DCI Server will be invisible to ordinary users, although they may indirectly use controls and functions that it provides.

In a similar way, the **Automation Server** (referred to as the AirChain Server in the block diagram) will be transparent to most users. This component provides the central point of control for automatic playout on a single transmission channel and communicates extensively with the DCI Server to send commands to, and receive data from, appropriate broadcast devices.

Neither the DCI Server nor Automation Server have user interfaces of their own. Instead, all configuration and control is carried out through one of the Automation Controllers, which can be run on any QSeries Client workstation. These controllers allow transmission to be initiated from a specified schedule and provides control and monitoring of all connected devices, or for news automation, provide simple playout control over a range of different device types and channels.

The **Standard Client** features powerful runorder management facilities which allow changes to be made quickly and easily. Extensive timing fields enable production staff to accurately time live broadcasts and see the affects of changes to the runorder straight away. The screen layouts can be changed, or new ones created, to suit individuals or groups of users. This means users can see all the information they need in a format they can easily follow. The printing of scripts and runorders is flexible and straightforward. As with the screen layouts, new print formats can be created and modified, with information such as story titles, page numbers and timing information organised in a way that suits the user. The software includes a security system to allow effective management of scripts and running orders. Users can be granted different levels of access to different areas of the system, allowing tight control of the system to be maintained. Client workstations will normally be connected directly to the QSeries DBServer, but remote users, or groups of users, can access the scripts and running orders via dial-up or dedicated lines.

The **Prompter Client** is like any other client workstation except it can also be used for prompting scripts. Using Autocue's Image Motion Technology card (IMT) the prompter produces smooth, high quality scrolling in PAL, NTSC and SECAM. Any changes made to the runorder or scripts are reflected on the prompter immediately, even within text currently displayed on the prompter output. The workstation can be used standalone if no network is available. Any language or character set used within the script is also displayed on the prompt output. The prompter can be configured to work in many different ways, depending on the preferences of the operator. The operator can choose the scroll control which suits them best, organise the screen for their favoured layout and set a large number of other preferences which affect the way the prompter works.

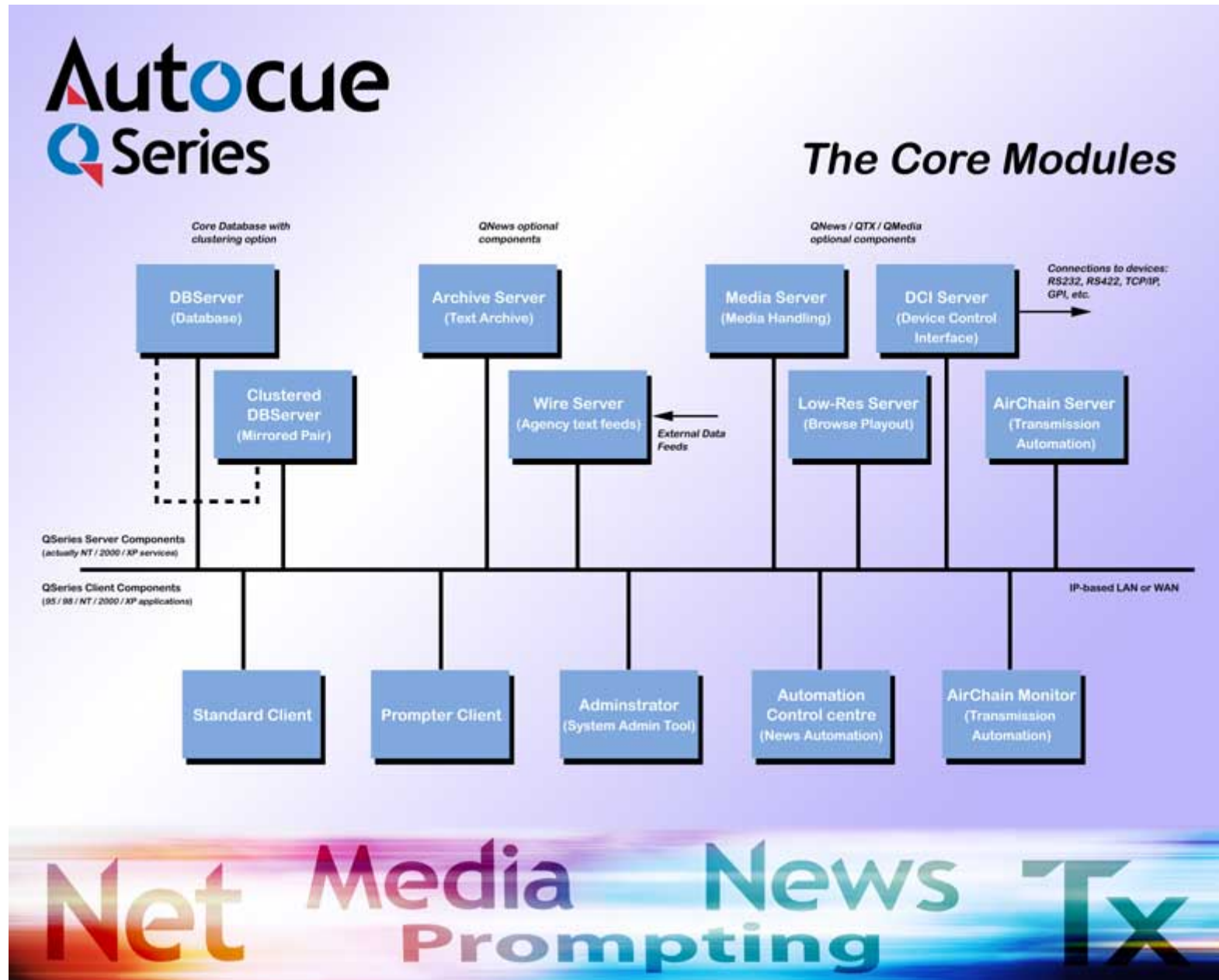

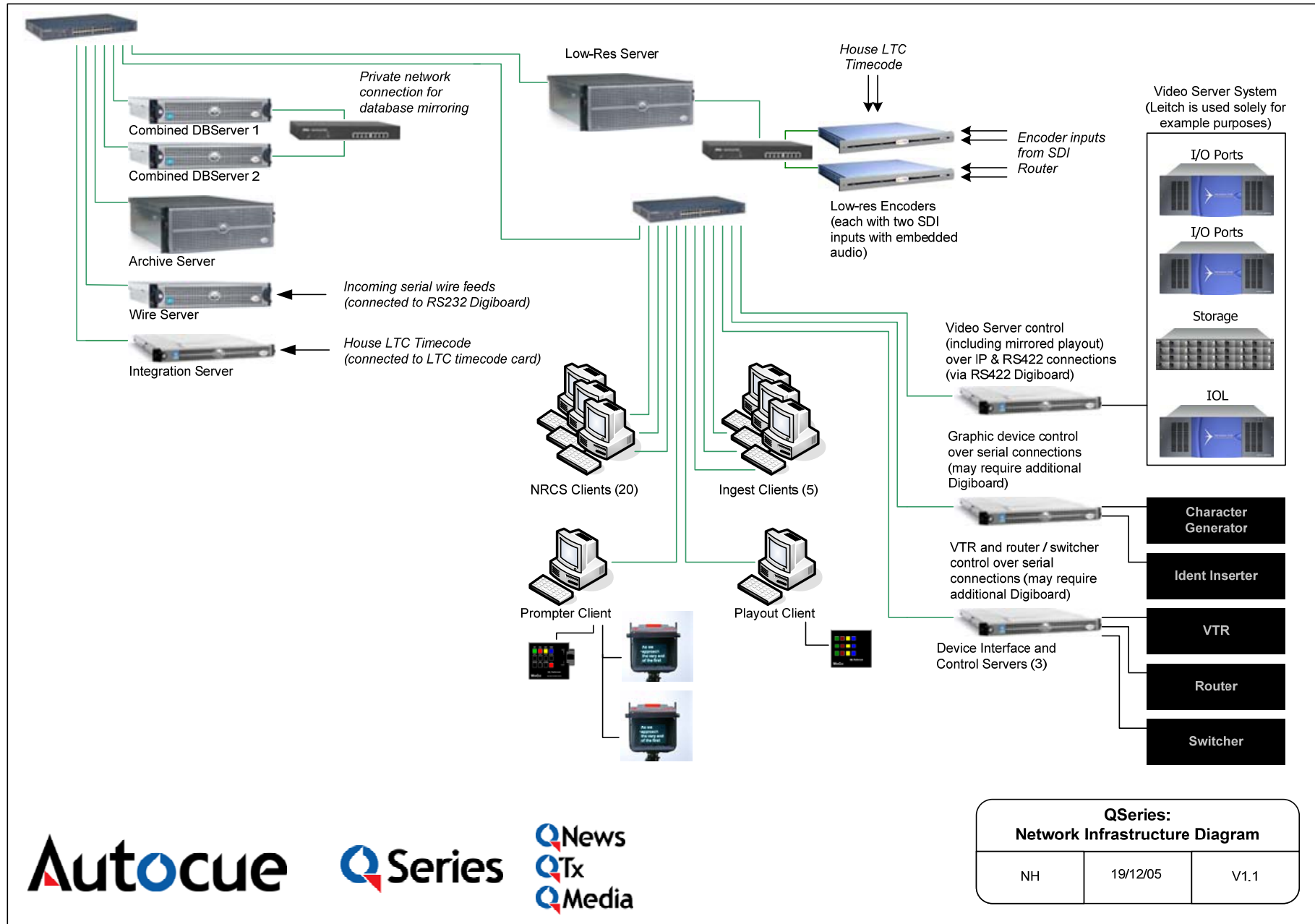

Autocue

QSeries

**QNews
QTx
QMedia**

3. WORKFLOW INFORMATION

3.1 Newsroom Workflow

3.1.1 Rundown Creation and Scripting (the QSeries Client)

The QSeries Client software is the common newsroom 'front-end' to the overall QSeries system, regardless of how the system is being used. An example of a Client screen is shown below.

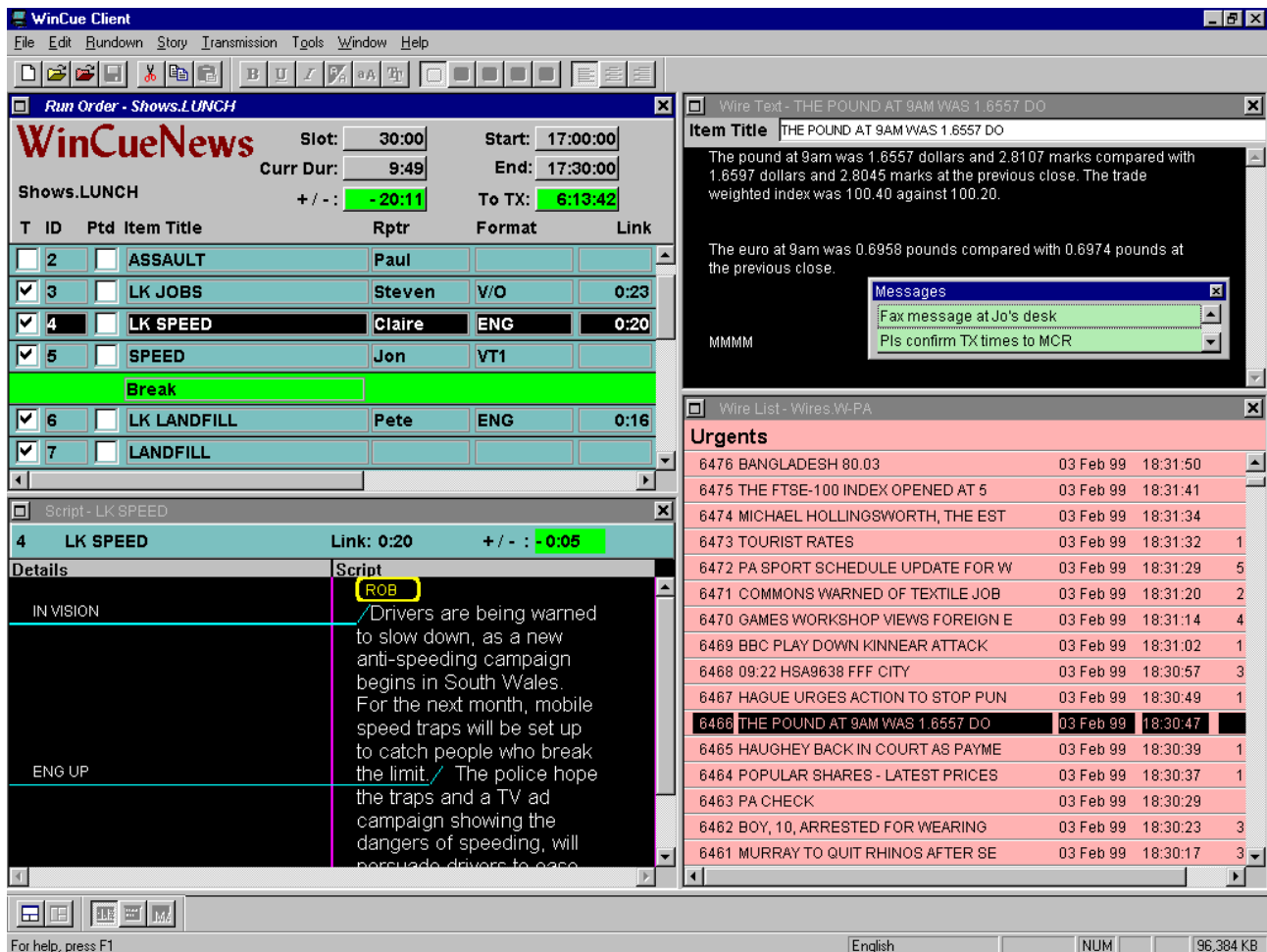

The Client is a completely standard Windows application, with the additional feature of being able to split the screen into 'panes'. Four panes are shown in the screen shot above, containing, respectively, a running order, a script, a list of wire stories and the text of a wire story. The number, size and arrangement of panes is defined by, and stored for, each individual user. Any single pane can contain more than one view, in which case 'tabs' at the bottom of the pane allow the user to switch from one view to another, and to move views between panes.

Almost every screen layout within the Client is customisable, both during initial configuration and subsequently by the customers themselves. This facility allows, for instance, a single running order to be viewed in different ways, as shown in the two examples below;

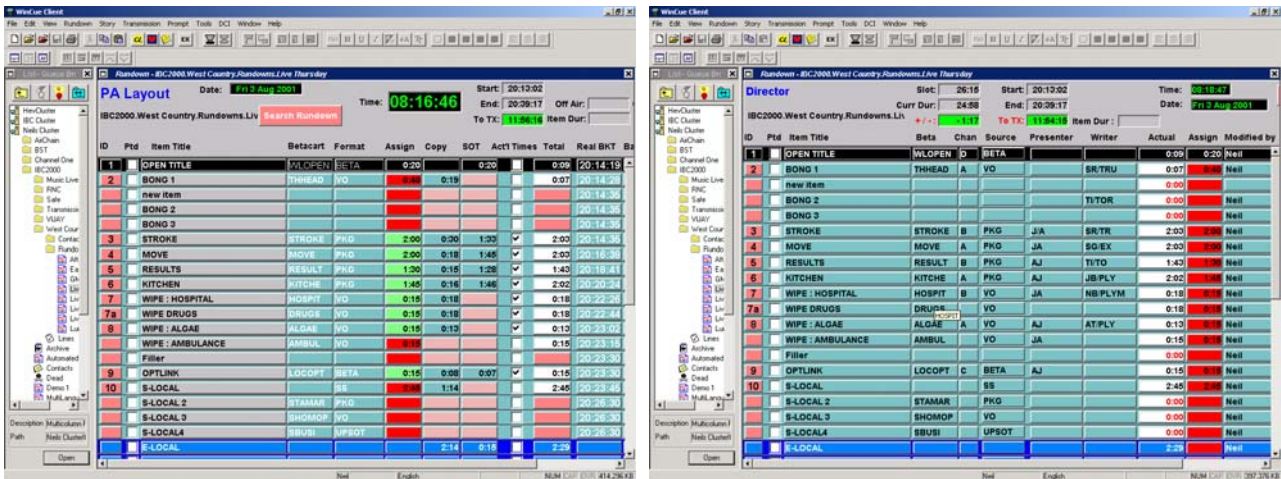

The Client allows both news-style running orders and transmission schedules to be created. Running orders allow a script to be permanently associated with each item (or 'slug'), and the flexible script editor allows these scripts to be entered in true multi-column format, as shown below.

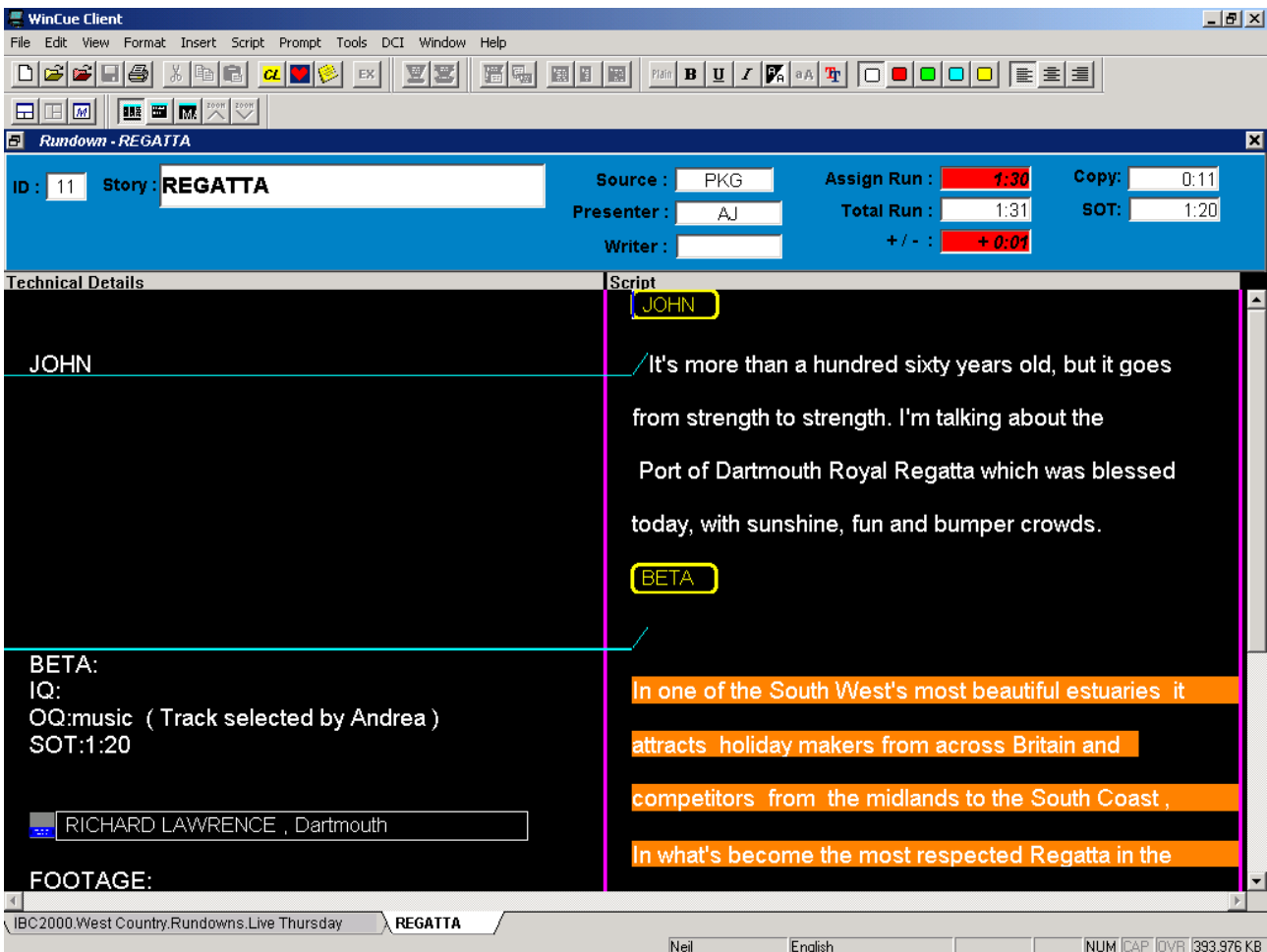

This news script uses just two columns, but the editor will allow up to eight. The format of each column is flexible; the default font size, colour, style, line spacing and overall width can all be configured to suit individual requirements. The view of the script can be customised, at any point, to allow all of the required information to be seen; in the example below the running order is displayed alongside a single column from the editor;

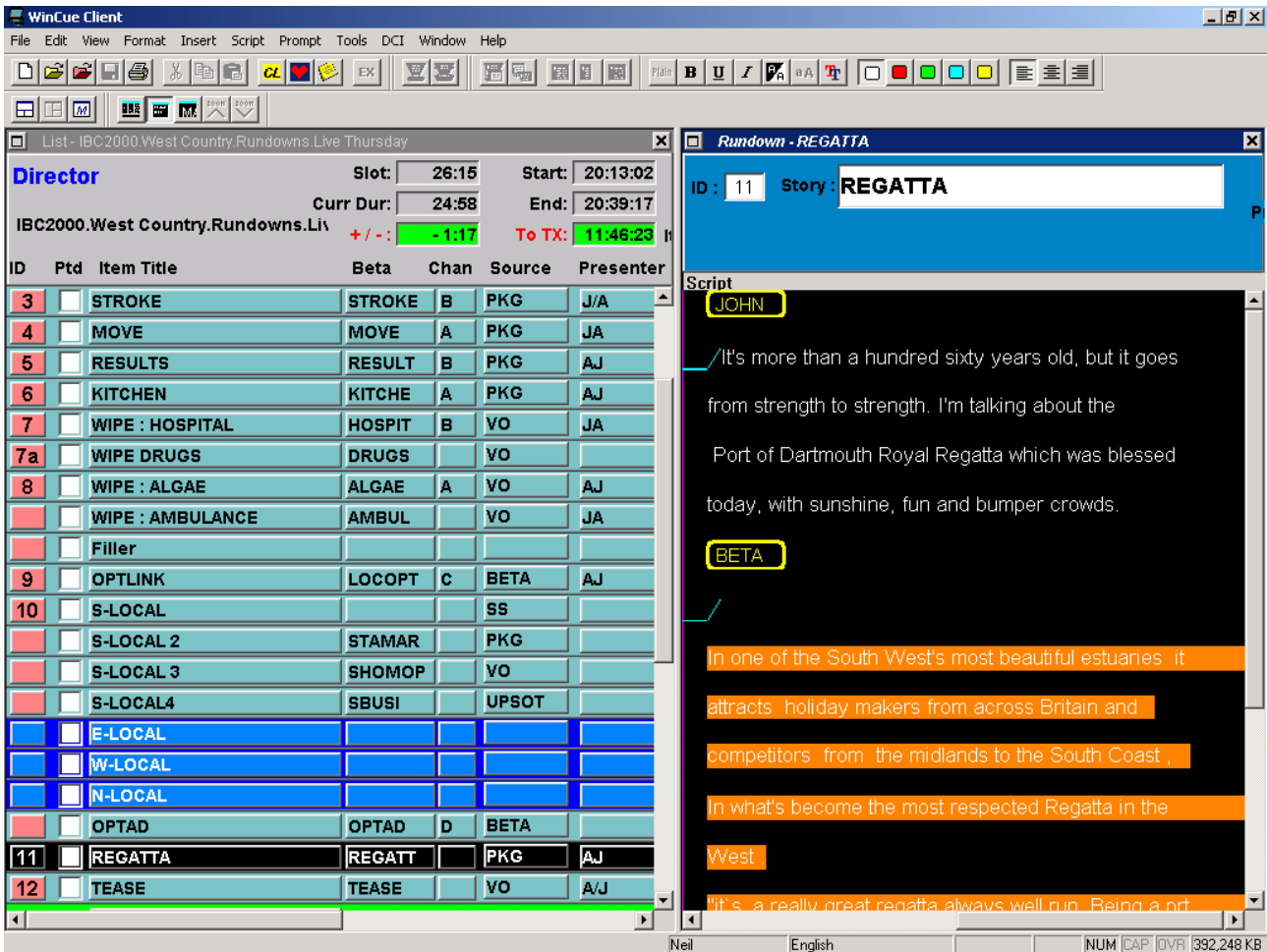

The yellow boxes indicate the presenter (or anchor) for that particular part of the script, and individual presenters can be set up with their preferred font, size, style and colour. It is also possible to define read rates for individual presenters, which means that the overall timing calculations for a script will be accurate even if it involves two or more presenters with different reading speeds.

The white text in the example above will appear on the teleprompter (which is an intrinsic part of the overall system) and will be sent for subtitling or to the closed caption encoder. The orange-backed text in this example will not be captioned, and it is also possible to mark text as 'not-prompted'.

Other types of 'queues' that the standard Client can use, in addition to running order queues, include Contact Lists (normally ordered alphabetically and intended to hold address or contact information), Assignment Queues (normally ordered by date and intended to be used as some form of diary) and Archive Queues (which are optimised to hold large amounts of old data, which is indexed to provide extremely fast searches). Examples of these three types of queues are shown below;

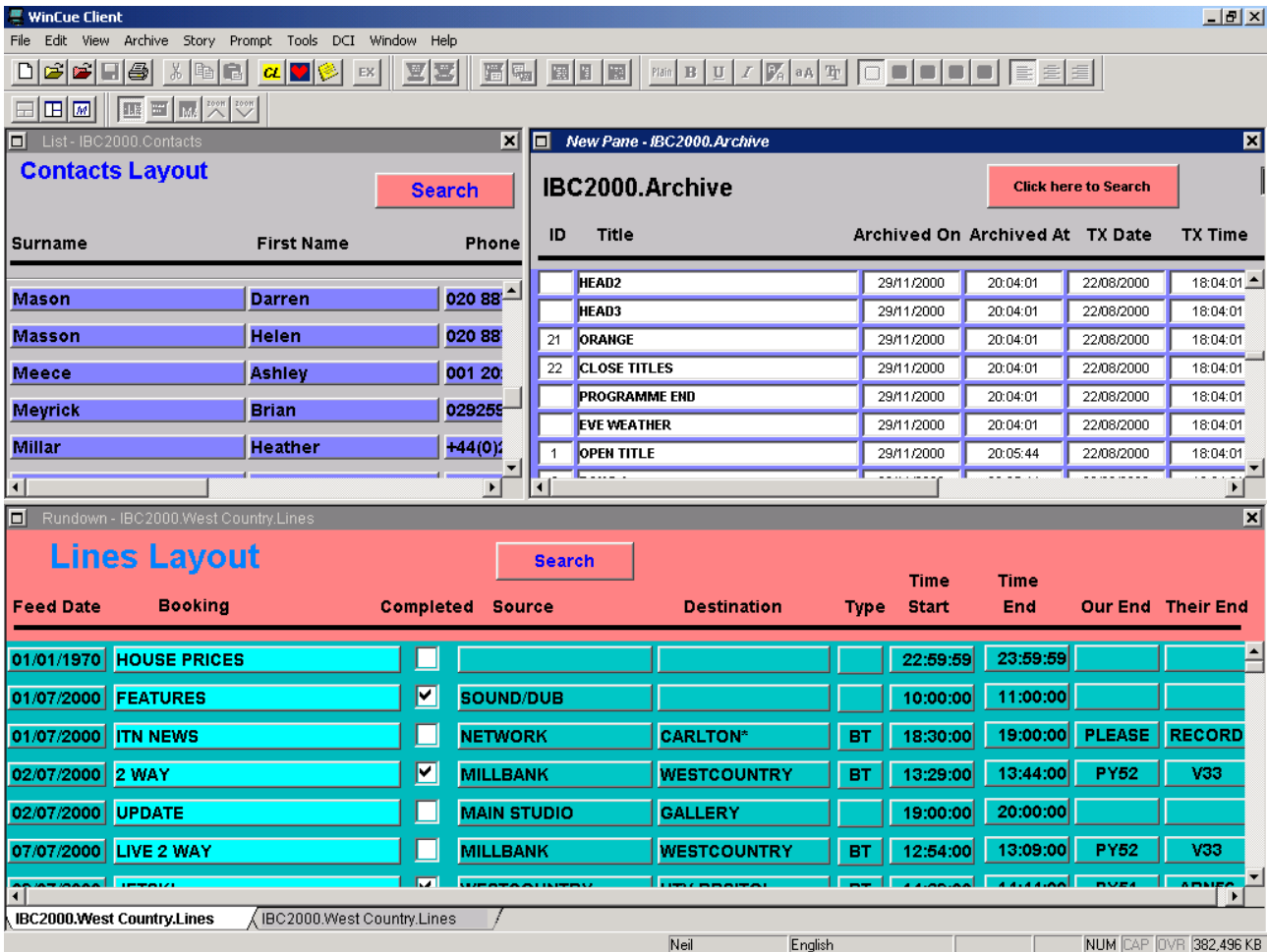

3.1.2 Text Archive

The QSeries incorporates ProIndex™ technology to provide extremely fast search facilities for even the largest of archives. Stories that need to be kept for future reference can be archived to a selected archive queue. The archiving process updates an index for that queue, allowing subsequent searches to be carried out by any user, from any client workstation. Searches can be specified based on words that occur in one or more item fields, or that occur within the script, or that are related in any way to the item. It is also possible to search for items that originated from a particular show, or where used over a particular period, or that were archived at a particular time. Items that were archived together can be displayed together, so individual programmes do not necessarily have to lose their identity within the archive as a whole. Search terms can include whole or part words and a wide range of Boolean search expressions. As with most other parts of the QSeries system, the archive search dialogue is a user-customisable layout that can be configured to the particular requirements of each group of users. One example of a search dialogue is shown below.

There are two different commands to move old items from their original rundown into an archive. One simply copies all selected items (or all items, if none is currently selected) into the specified archive queue. The other carries out a more complex procedure on the entire queue (regardless of the current item selection), and can include the following steps;

- if necessary, copy the contents of the rundown to another location (for immediate access as a backup copy), then,
- copy each item tagged as 'for archiving' to the archive, for all items in the rundown, then,
- delete, clear (delete all script information) or leave each item in the queue, based on the properties of each item, then,
- if necessary, copy a rundown from another location into this queue (to provide a template for the next show).

This 'daily archive' process provides a quick and easy way to prepare the rundown for the next show.

3.1.3 CG Device handling

It is also possible to insert a number of types of 'automation event' into the left-hand column of a script. A typical example of an automation event would be a caption (or lower-third), which allows a user to enter the text to be displayed in the final on-screen caption. It is important to note that the way in which the caption appears on-screen is entirely defined by the template contained within the character generator device – i.e. fields, locations, fonts, styles, sizes, effects, etc. are all a function of the CG. The functionality provided within the QSeries Client is simply a short-cut to entering text on the CG device directly – it is far more convenient for a journalist to enter a name and location, for instance, directly from their newsroom workstation while editing the appropriate script, rather than having to pass the information to the CG operator to be retyped.

The process to enter a new caption is very straightforward: a number of alternative short-cut keys, menu commands or context menus can be used to call up a list of appropriate CG devices (this stage is skipped if only one device is configured), followed by a list of relevant captions styles (e.g. top-left, top-right, one-line, two-line, three-line, etc.). The user chooses the appropriate style name, and is then presented with a template that represents the actual caption – which ensures that they have chosen the correct style, and that they don't accidentally enter too much information to fit in the available space. An example of a simple two-line caption is shown below left.

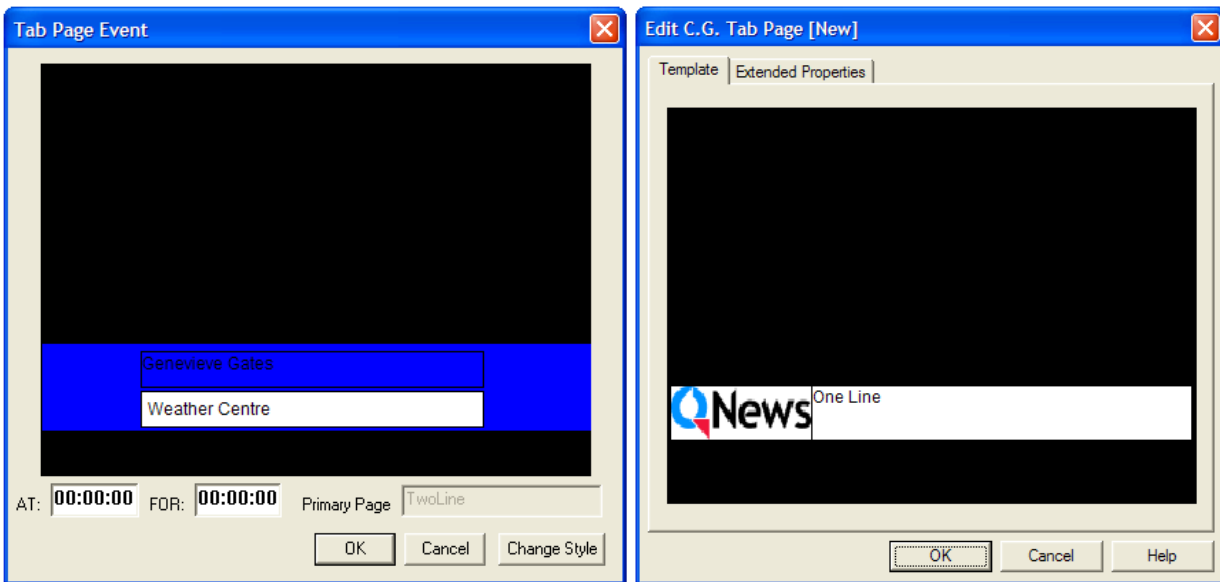

The templates used to enter caption information are designed using the QSeries Administration application, using the layout editor shown above right. This allows fields, fonts, styles, sizes, locations and bitmaps to be configured to represent the actual CG output as closely as possible.

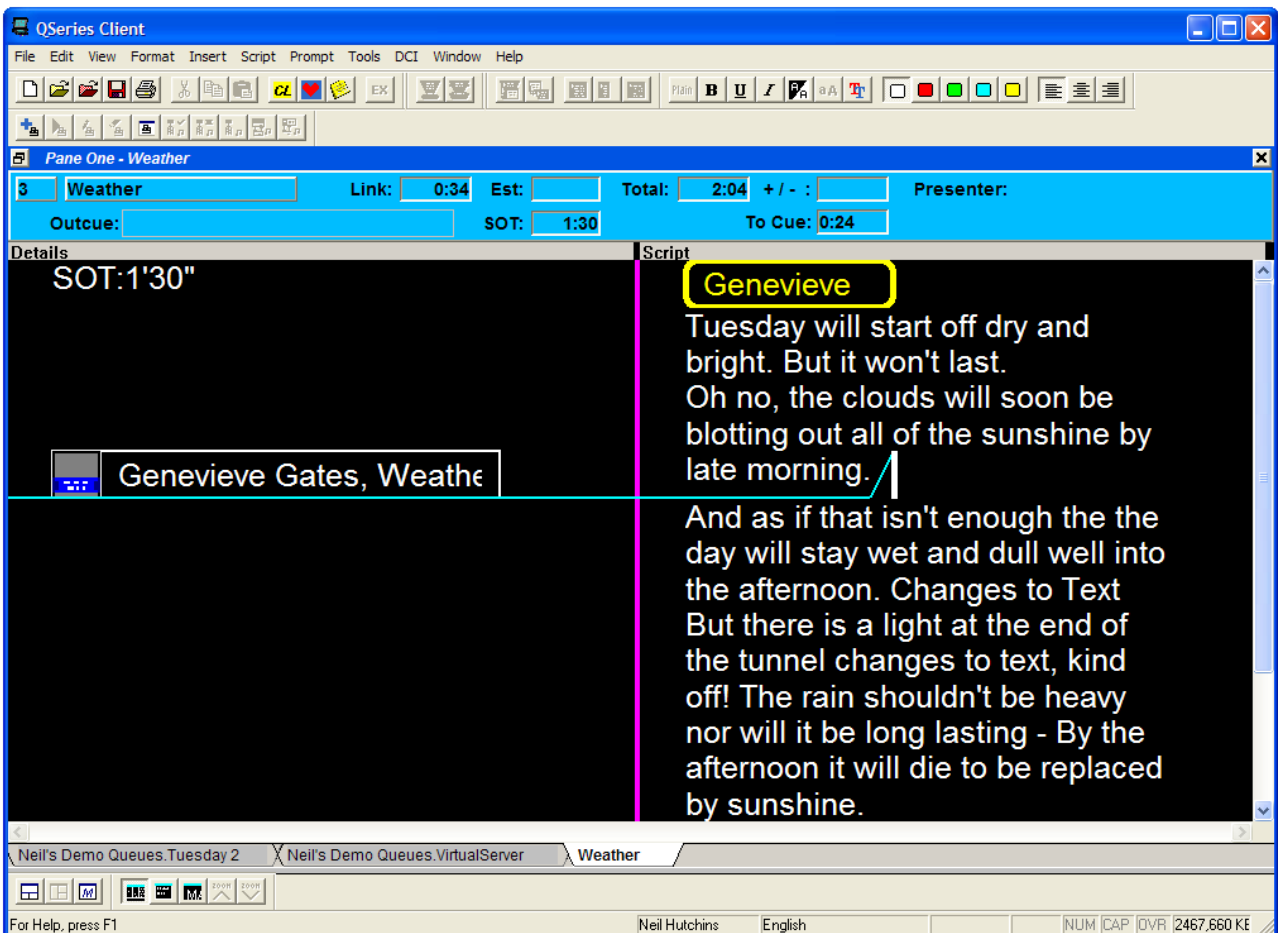

Once a caption has been entered into the appropriate template, it appears as a CG Event on the left-hand side of the script, as shown above. The blue 'cut-line' in the example is optional, but can be used to indicate the precise position at which the caption is to be used. An existing caption can be modified by double-clicking it, which causes the original template to appear, pre-filled with the current text information.

3.1.4 Video Clip Selection and Definition

Another type of automation event, similar to the caption events described in the previous section, are video events. These most commonly relate to video material stored on a video server, and as such the description below is based on server-based video clips, however they can also be used to refer to material recorded on tape.

A video event refers to a single piece of material, and includes information to specify the name of that clip and (optionally) the in- and out-timecodes for this instance of the material. The ability to define in- and out-points for a clip means that different parts of a single clip can be used at different times. For instance, a single clip might contain material that starts at 10:00:00:00 and finishes at 10:05:00:00, and therefore have a duration of five minutes. It might be appropriate to use thirty seconds of that clip (perhaps 10:00:10:00 to 10:00:40:00) during a headline sequence and almost all of the clip (perhaps 10:00:05:00 to 10:04:59:30) during the associated package. The ability to define different in- and out-points for different video events allows the same clip to be used in different ways without having to produce different edited versions of it. If timecodes are not specified, the clip starts playing at it's hard in-point (10:00:00:00 in this example) and continues playing until it reaches its end-point or is stopped.

Video events differ slightly from caption events in that they can appear both in the script and at the rundown level (caption events can only be entered within scripts). However, the selection of material is the same in both cases – the user chooses the required clip from a drop-down list which can be set to show text details or simple thumbnail images for each clip, illustrated by the two screen shots below. The left-hand image shows thumbnail images being used to select a video clip for use in a script. The right-hand image shows the detailed version of the clip list, including information about the clip name, description, duration and video server, which also provides the ability to search for clips, order the information in different ways and filter the number of items displayed.

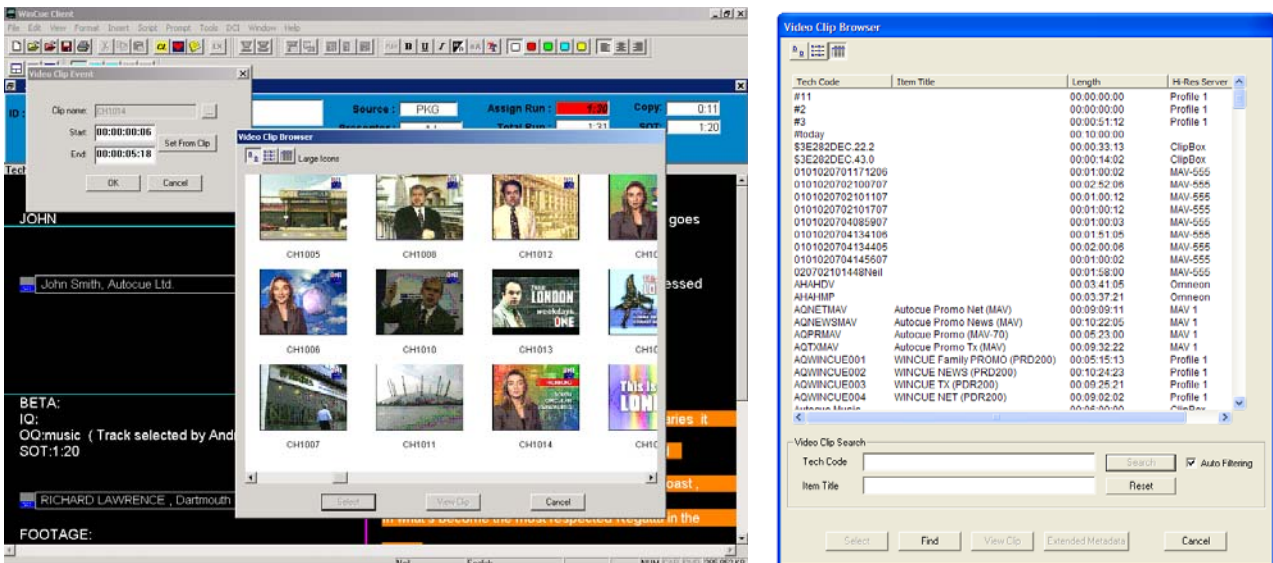

The selection process for video clips is the same, regardless of whether the clip is to be placed at the rundown level or within the script. The image below illustrates three rundown items, each with one associated video clip. Once an association has been made, that video clip is permanently linked to that rundown item, meaning that the order of clips changes as the rundown is re-ordered and the clip is deleted or copied if the rundown item is deleted or copied. The button marked with down-arrow is the 'browse' command – allowing the user to choose another clip to be associated with this item.

5	<input type="checkbox"/>	Link Spymaster	CH1001	▼	View	00:00:01:05	00:00:21:22
3	<input type="checkbox"/>	Weather	CH1006	▼	View	00:00:01:08	00:00:30:03
7	<input type="checkbox"/>	Sports	CH1011	▼	View	00:00:00:06	00:00:12:18

The image below illustrates a video event that has been added within the script. The event can be modified (e.g. to choose another clip or change timecodes) by double-clicking the icon. As described above, the blue 'cut-line' is optional, and can be used to indicate exactly where in the script the clip should be played.

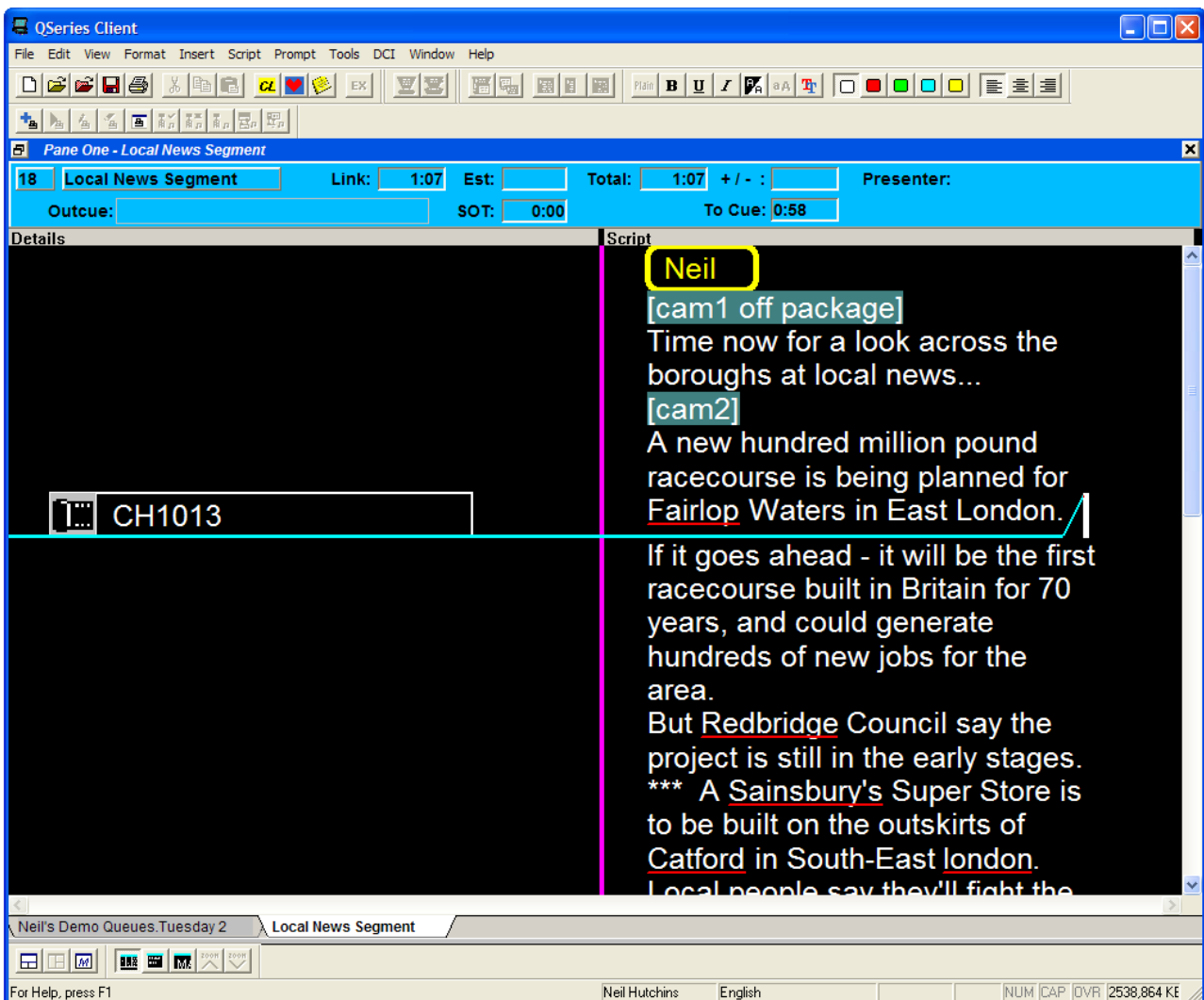

There are a number of practical differences between scripts placed at the rundown level compared with those entered within a script. These include the fact that a rundown item can contain a maximum of four clips, each associated with one of four specific 'slots' for that item, whereas a script can contain an unlimited number of clips, and that clips at the rundown level can display status (e.g. missing, OK, cued, playing, on-air, etc.), whereas clips within a script cannot. One further difference is related to the use of placeholders. The description so far has referred to the ability to select a video clip from a list of clips that already exist on the video server. This is a good methodology, as it only allows material that actually exists to be chosen, and does not require a clip name ever to be entered manually – as this can lead to errors, including confusion between lower and upper case characters, '0' and 'O', 'i' and 'l' and simple typing errors. However, this process does not work if a Producer, for instance, wishes to define the name of a clip that does not yet exist. To achieve this, the QSeries clip database includes the concept of 'placeholder' clips: entries in the database that 'reserve' a

place for a piece of video to be created in the future, perhaps as an edited package or scheduled line feed. The final difference between rundown and script clips is that placeholder clips can be created at the rundown level but not within a script.

The screenshot below gives an example of entering a placeholder into a rundown item. The dialogue box allows a placeholder name to be entered manually (or set automatically), provides a description (which can include the rundown name) to assist with the identification of the item by other users and allows an estimated duration to be assigned to the item.

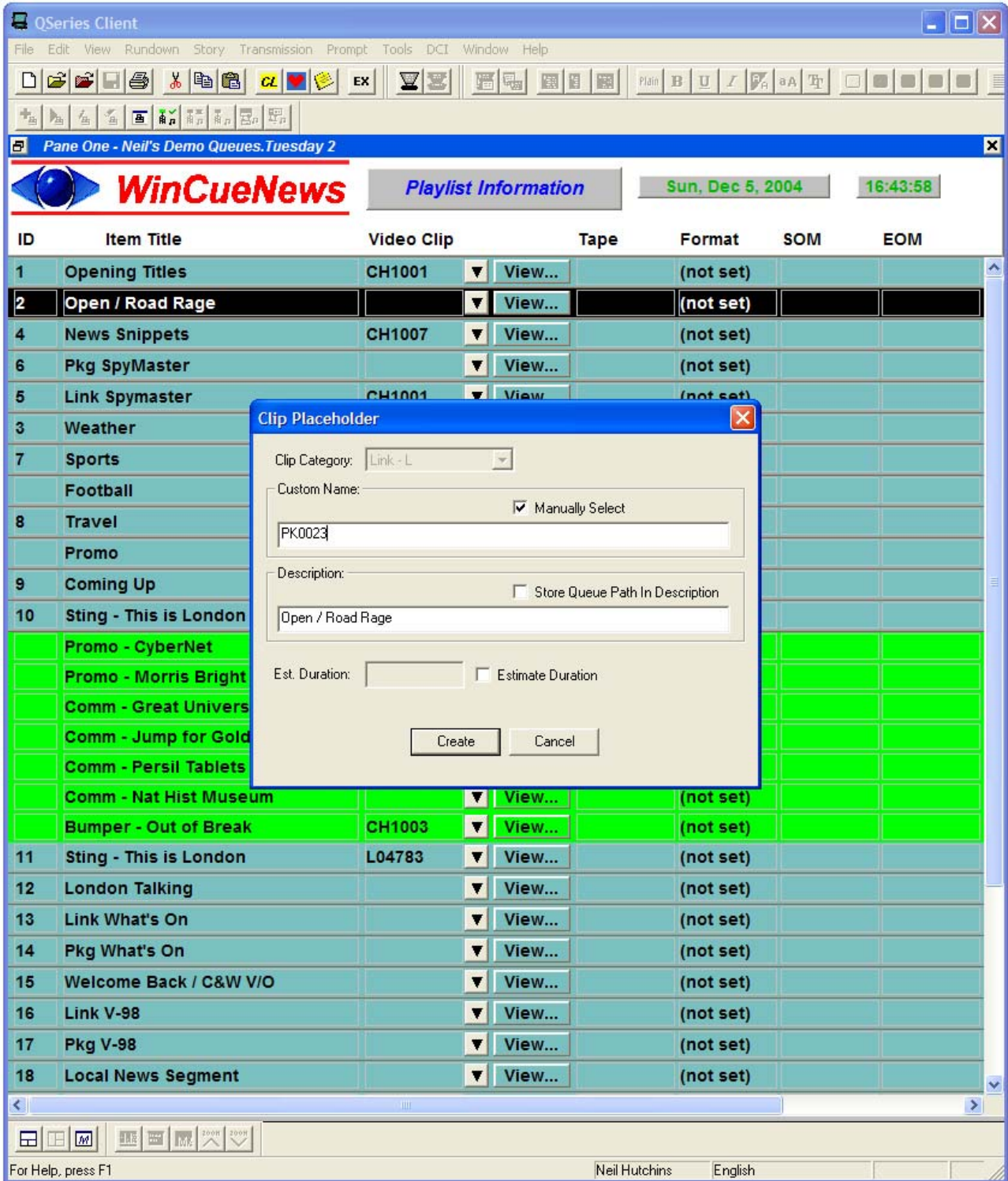

A more detailed description of placeholder handling, plus additional information relating to video clip workflow, is included in Appendix A.

3.2 Media Handling

This section describes some of the media handling capabilities of the QSeries system, including ingest, review, archiving, low-resolution handling and simple shot selection.

Media Handling functionality is provided by the QSeries **Media Station** application, which is the main user interface to the information within, and the actions related to, the QSeries video clip database. MediaStation is a true network application that can be run on any network PC (where the software has been installed) by any user with appropriate security access. It is a standard Windows application, making it obvious to use, and it follows the conventions of other QSeries applications.

3.2.1 Media Database

The core element of media handling is the **Clip Database**, which contains information about all stored video, regardless of location: on-line servers, archive servers, low-resolution systems, tape backups, etc. The structure of the database is designed to control the use and transmission of individual items. The database is stored within the main server cluster to protect it against hardware failure.

The contents of the Clip Database can be viewed in a number of configurable ways, including the detailed list and thumbnail views shown below.

The Clip Database is vital to the smooth operation of all aspects of the news and automation functions. It is important that it contains enough information to track material at any stage of its life, and that the up-to-date information it contains is available to all processes that require it.

The QSeries Clip Database has two basic principles; that every clip that is to be used by any module must have an entry within the Clip Database, and that once an item has been stored within the Clip Database, it will never be deleted. The database also uses the concept of *Absolute* and *Marked* Timecodes. Absolute timecodes define the complete clip, marked timecodes describe a portion of the clip. The main difference between absolute and marked timecodes is that slugs using absolute timecodes will always inherit those timecodes from the Clip Database. Therefore, if the video is altered for any reason, all slugs using the absolute timecodes will automatically inherit that change. This is important because one clip may be used over and over again in different running orders, and a change in timecode would require the user to search every queue to find every instance. Conversely, slugs using marked timecodes will continue to use those values, even if the absolute timecodes are changed.

Title	ID	Description	Default First...	Default Last...	Default Duration	Creation Date/Time Short
14/03 CHARMINAR	2,460	--no description--	00:00:00:00	00:01:37:07	00:01:37:08	14/03/2003 05:15:40
14/03 euphoria	2,525	--no description--	00:00:00:00	00:00:13:06	00:00:13:07	14/03/2003 10:04:41
14/03 FARMERS PROTEST PKG	2,530	--no description--	00:00:00:00	00:01:32:15	00:01:32:16	14/03/2003 10:38:29
14/03 INDINZ	2,469	--no description--	00:00:00:00	00:00:10:07	00:00:10:08	14/03/2003 05:44:51
14/03 INDIA GATE WALK THROUGH	2,513	--no description--	00:00:00:00	00:00:52:17	00:00:52:18	14/03/2003 09:38:21
14/03 INJURED HEADLINE	2,467	--no description--	00:00:00:00	00:00:07:24	00:00:08:00	14/03/2003 05:33:35
14/03 INJURED PKG	2,473	--no description--	00:00:00:00	00:01:26:16	00:01:26:17	14/03/2003 05:55:36
14/03 INJURED PKG NEW	2,519	--no description--	00:00:00:00	00:01:26:15	00:01:26:16	14/03/2003 09:51:27
14/03 IRAQ LEAD PKG	2,459	--no description--	00:00:00:00	00:01:59:20	00:01:59:21	14/03/2003 05:11:46
14/03 IRAQ LEAD PKG NEW	2,518	--no description--	00:00:00:00	00:02:03:14	00:02:03:15	14/03/2003 09:49:54
14/03 JAIPUR TOURIST PKG-STORY	2,899	PKG	10:00:02:21	10:01:06:03	00:01:03:08	15/03/2003 06:21:34
14/03 MP CRIMINAL PKG	2,421	--no description--	00:00:00:00	00:02:20:03	00:02:20:04	14/03/2003 03:45:41
14/03 MP CRIMINAL PKG NEW	2,516	--no description--	00:00:00:00	00:02:03:15	00:02:03:16	14/03/2003 09:39:54
14/03 MP CRIMINAL PKG NU	2,517	--no description--	00:00:00:00	00:02:22:05	00:02:22:06	14/03/2003 09:47:53
14/03 ORISSA PKG-STORY	2,891	PKG	10:01:15:22	10:02:44:20	00:01:28:24	15/03/2003 06:23:27
14/03 ORISSA PKG-TEASE	2,890	PKG	10:02:47:17	10:02:55:12	00:00:07:21	15/03/2003 06:22:56
14/03 PREITY ZINTA SOT	2,514	--no description--	00:00:00:00	00:00:30:13	00:00:30:14	14/03/2003 09:38:21
14/03 PREITY ZINTA VO	2,512	--no description--	00:00:00:00	00:00:56:02	00:00:56:03	14/03/2003 09:35:11
14/03 PREITY ZINTA1 VO	2,515	--no description--	00:00:00:00	00:00:56:02	00:00:56:03	14/03/2003 09:38:23
14/03 SERBIA VO	2,468	--no description--	00:00:00:00	00:00:40:17	00:00:40:18	14/03/2003 05:40:13
14/03 SERBIA VO FILM	2,517	--no description--	00:00:00:00	00:00:24:24	00:00:25:00	14/03/2003 06:00:03
14/03 SION HOSPITAL PKG	2,919	PKG	00:15:10:05	00:16:14:20	00:01:04:16	15/03/2003 07:18:55
14/03 student activities	2,303	--no description--	00:00:00:00	00:01:34:07	00:01:34:08	14/03/2003 03:24:49

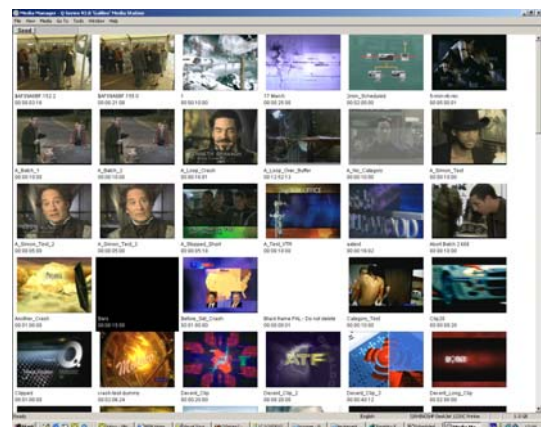

3.2.2 Ingest

Ingest can be managed from any workstation via the **Media Station** client application. This provides the user with control over appropriate devices in order to load material onto one or more video servers.

Different types of material will be loaded at different times and in different ways: three possible scenarios are described below;

a) As-live' material

Some material may need to be recorded into the video server 'as-live', with the TechOp or Director manually controlling the vision mixer, sound desk etc. In this situation, the Media Station client application collects the required resources, allocates an appropriate clip ID, opens a record channel and provides simple controls to start and stop recording. Once the item is complete, the TechOp can review the recording, mark in- and out-timecodes, trim and store the new clip.

b) Pre-edited Items

Complete items on tape, which have been edited elsewhere, may need to be loaded onto the video server in their entirety. If the Technical Operator (TechOp) places the tape into an available VT machine and enters the appropriate in- and out-points for the item, the system automatically records the item onto the server. Once complete, the appropriate information is added to the Clip Database.

c) Press Agency video feeds

Feeds from agencies or other providers may be scheduled for specific times of the day, and will be automatically recorded onto an available server channel with an appropriate clip ID. If scripts are sent with the agency video, a Wire Server will collect the text and make it available within the scripting system, allowing the recorded video to be associated with appropriate scripts.

These three different ingest processes are illustrated in the screen shots below;

Ingest can be initiated from a menu command, toolbar buttons or customisable short-cut keys:

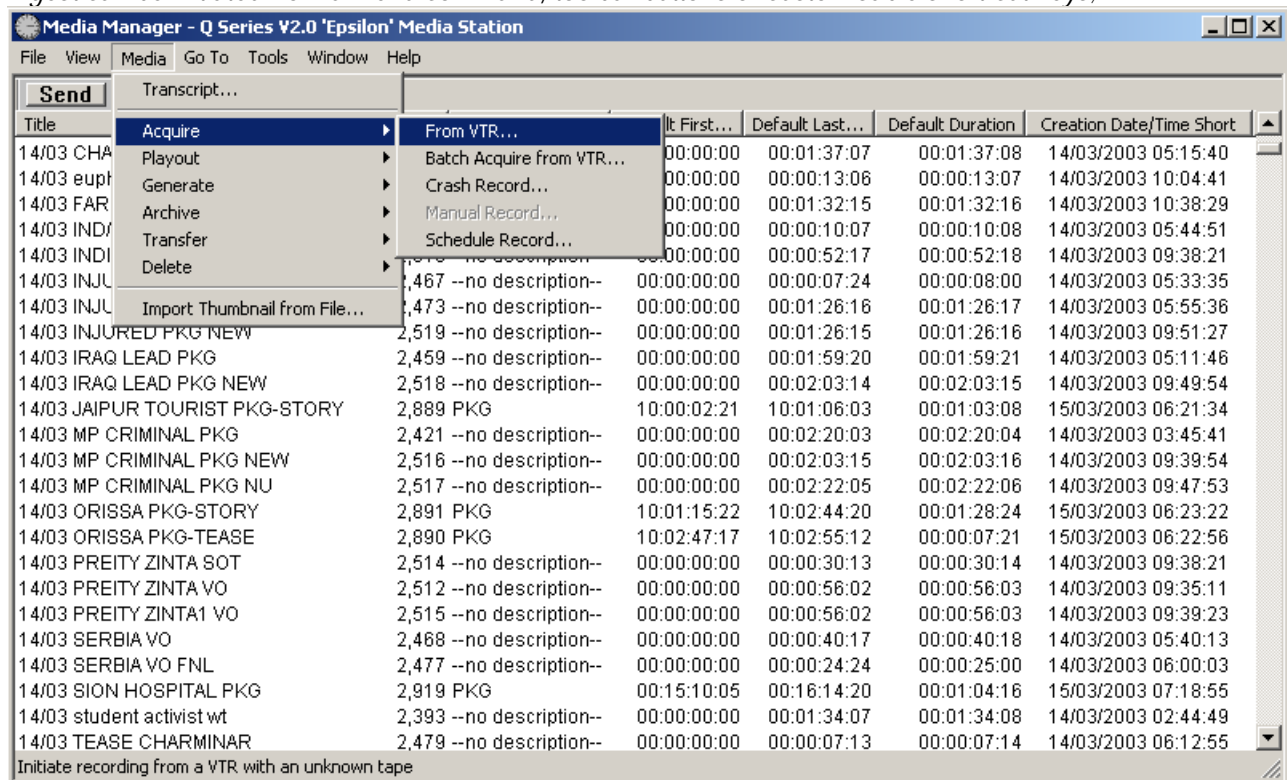

Crash record allows the operator to choose a source or specific server port and manually start and stop recording;

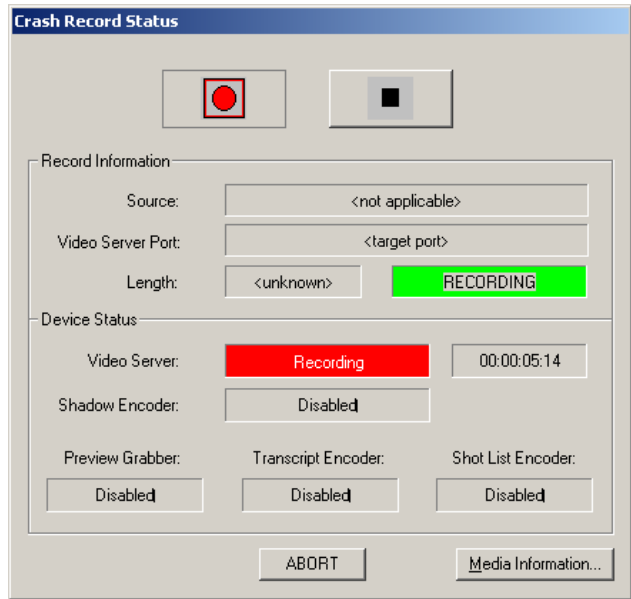
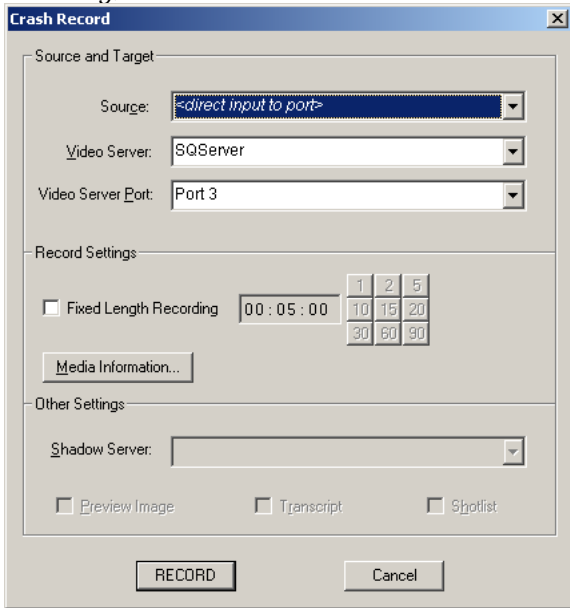

Record from VTR allows the operator to choose a specific tape machine, server port and to mark in- and out-points;

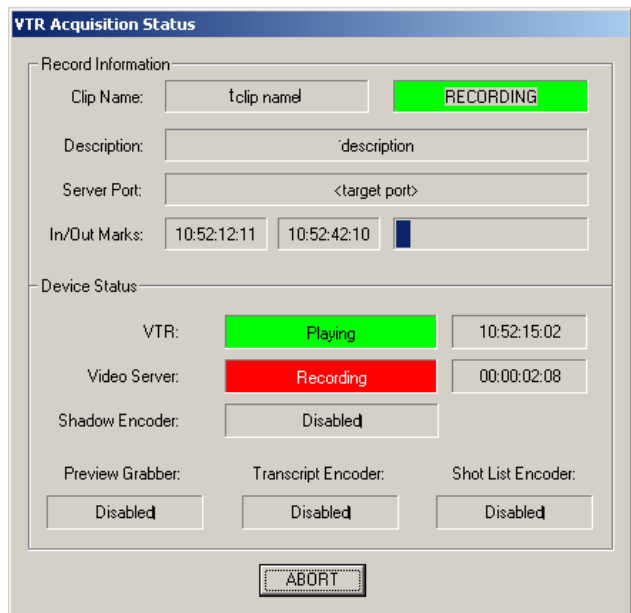
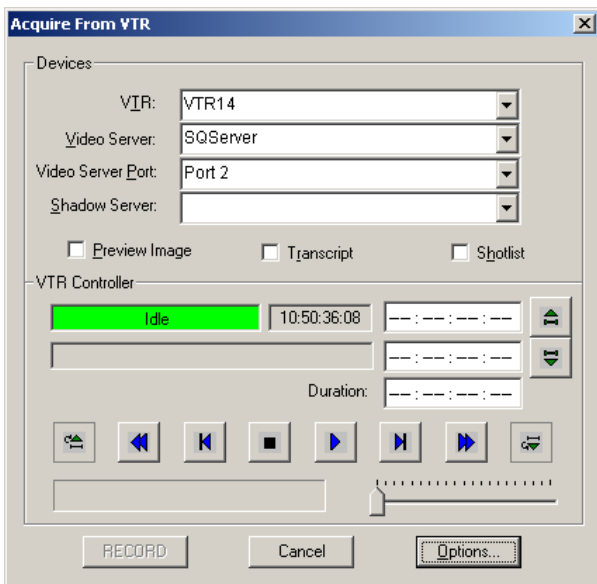

Batch record from tape allows multiple segments from the same tape to be recorded automatically in one sequence;

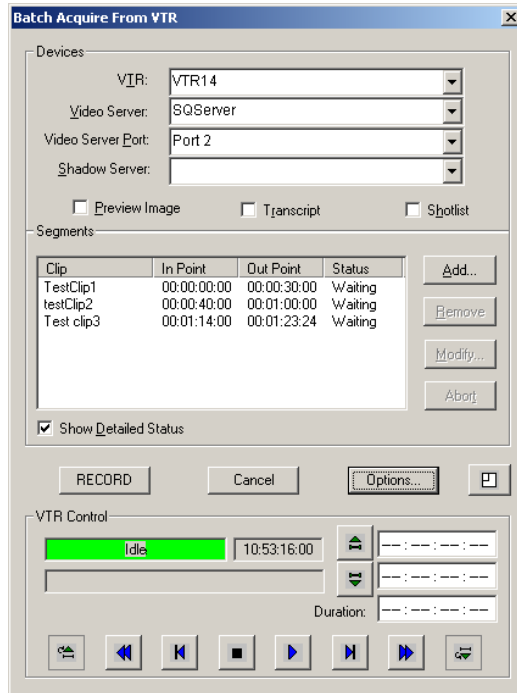

Scheduled recording allows a date, time, duration, clip ID and repeat information to be entered, and then subsequently reviewed in a customisable diary view;

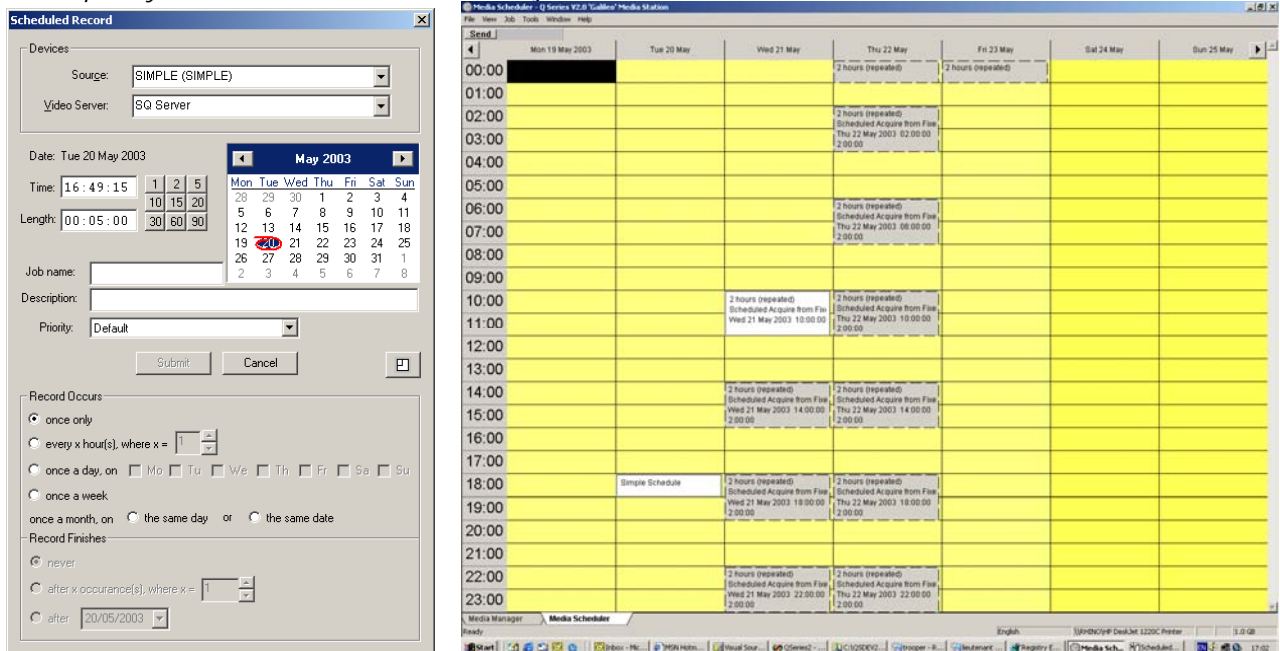

Clips can be reviewed (i.e. played out under manual control) at any time – even during recording in most cases – on a specified server channel;

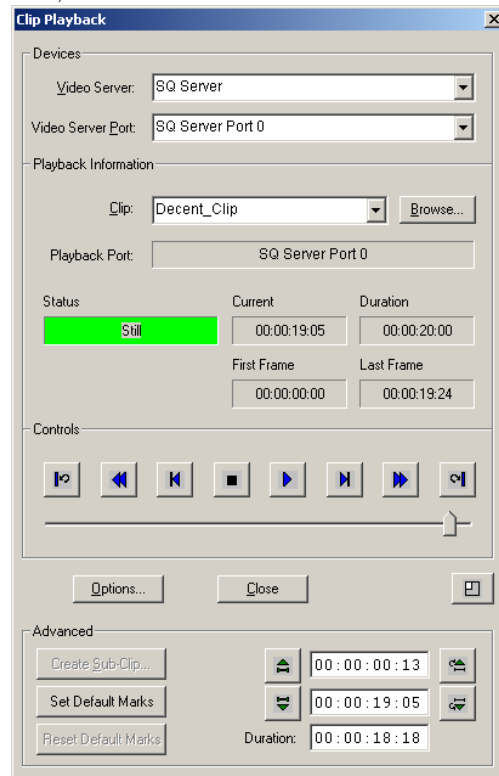

3.2.3 Archive to VTR

A simple option for archive functionality is to transfer video clips to tape. The Media Station client application allows one or more selected clips to be recorded (as baseband video) on tape using a standard VTR. The process is described below.

- 1) The user selects one or more clips from the current material on the video server for archiving. Multiple clips can be selected in contiguous or non-contiguous blocks.
- 2) The user selects the VTR to be used for the archive process (if more than one is present within the QMedia configuration). It is not necessary to select a playout port on the video server, as the process will automatically select an appropriate port based on availability and suitability (capability flags within the port configuration can be used to define the range of functions that any particular port can be used for). Once a VTR (the destination) has been defined by the user, and an appropriate port has been chosen automatically, the software will set up an appropriate path through the router.
- 3) The user defines the archive tape to be used for this set of clips. A drop-down box is available that contains all existing entries within the tape library. If necessary, the user can create a new tape to be used. The record for a new tape will include the following information; Tape ID, Tape Name, Format (e.g. Beta SX), Video Standard (e.g. PAL), the first usable timecode (the tape must be pre-stripped with continuous timecode) and Tape Duration.
- 4) The software will ask for the correct tape to be loaded, and after confirmation will cue the tape to the correct point – which will be a fixed offset (e.g. 10 seconds) after the end of the last clip to be recorded.
- 5) The software will create a playlist of the selected clips on the single playout port, with a pre-selected clip used as a separator between each item.
- 6) The software will trigger recording on the VTR and playback on the video server. Once all of the clips have been recorded, the server port will be reset and the tape will be ejected.
- 7) Having completed the archive to tape process, each of the clip records in the QSeries video clip database will be updated to include the tape and timecode details of the archived item.

8) Subsequently, users can search for archived items using the tape library functionality provided within the QMedia application. Where QNews is in use as the NRCS, it will also be possible to obtain references to the archive tape from within the main script archive.

This functionality is illustrated in the four screen shots below;

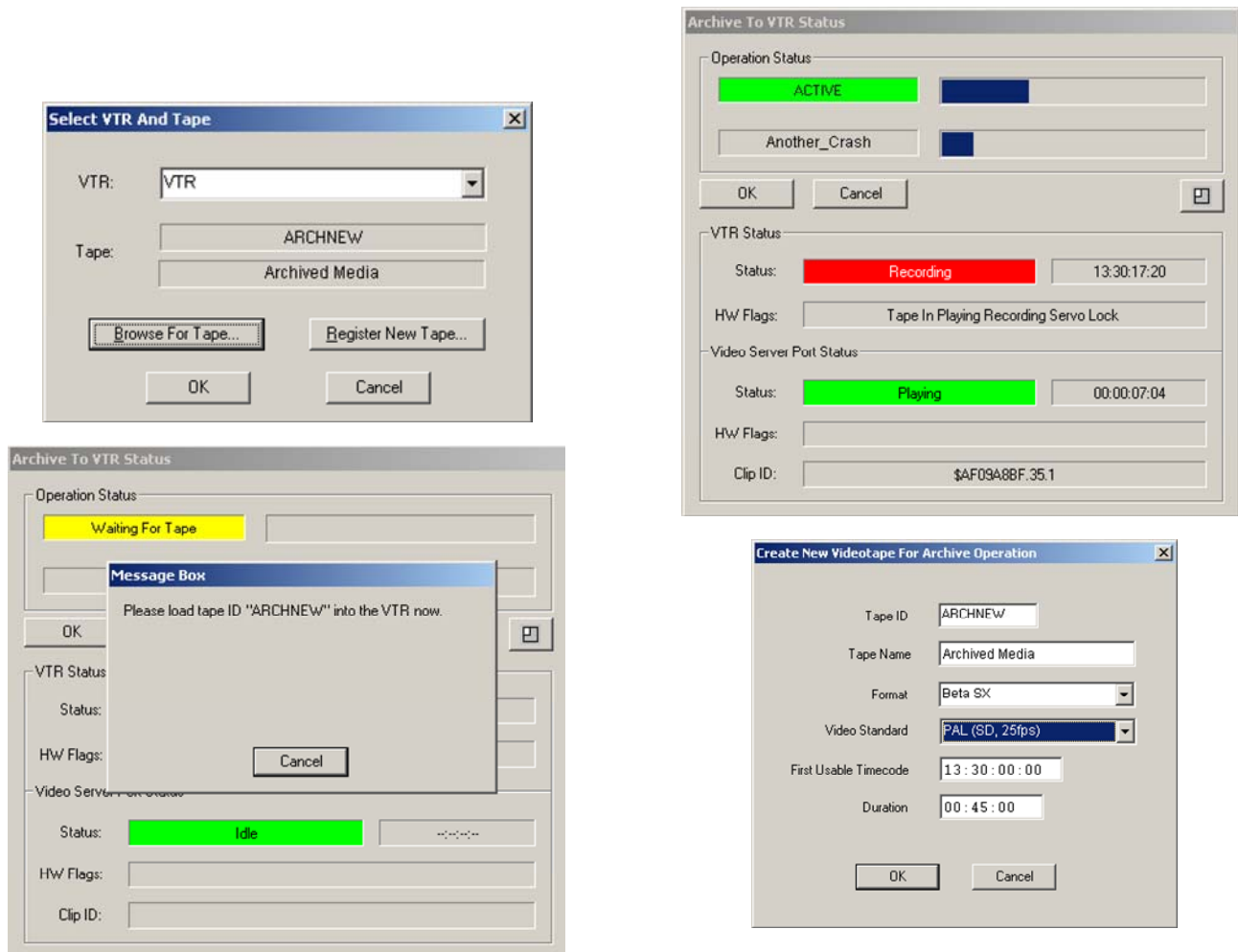

3.2.4 Low-res Handling

QMedia provides a number of media handling and management functions. One of these is low-resolution browsing, either at frame-accuracy to allow clip trimming or editing or at very low-res for content checking.

The low-resolution material is stored as MPEG-1 files in a range from 200Kbit/s to 2.5 Mbit/s with two audio channels. The low-res files are generated through hardware encoders with SDI or composite video inputs and can be played back by any player capable of MPEG-1 playback, including Windows Media Player and Apple QuickTime. However, browsing of the low-res files is also an integral part of the QSeries client components, where the user is able to select material based on the information from the video clip database, and where it is optionally possible to make frame accurate changes to the original high resolution material - for instance, to create a new clip based on a marked portion of an existing item. The frame accurate browser incorporated into the QNews client is illustrated below;

The screenshot displays the WinCue Client interface. The main window is titled "Rundown - IBC2000.West Country.Rundowns.Live Thursday". It features a menu bar (File, Edit, View, Wire, Prompt, Tools, DCI, Window, Help) and a toolbar with various icons. Below the menu is a "Clip Names" section with a logo and a table of items. The table has columns for ID, Ptd, Item Title, Clip, and SO. The "BBC Headlines" item is selected. To the right, a "List - IBC2000.W-PA - All" window shows a search bar and a list of clips with columns for title, ID, start time, and duration. Below this is a "New Pane - Shadow Video Viewer" window showing a video frame with a large number "1" and the "BBC NEWS" logo. A video control bar at the bottom of the viewer shows a timecode of 13:00:34:19 and various playback controls. The status bar at the bottom indicates "Neil English" and "NUM CAP OVR 343,616 KB".

ID	Ptd	Item Title	Clip	SO
1	<input type="checkbox"/>	OPEN TITLE		View
2	<input type="checkbox"/>	BONG 1		View
	<input checked="" type="checkbox"/>	BBC Headlines	BBCTVC010	View
	<input type="checkbox"/>	BONG 2		View
	<input type="checkbox"/>	BONG 3		View
3	<input type="checkbox"/>	STROKE		View
4	<input type="checkbox"/>	MOVE		View
5	<input type="checkbox"/>	RESULTS		View
6	<input type="checkbox"/>	KITCHEN		View
7	<input type="checkbox"/>	WIPE : HOSPITAL		View
7a	<input type="checkbox"/>	WIPE DRUGS		View
8	<input type="checkbox"/>	WIPE : ALGAE		View
	<input type="checkbox"/>	WIPE : AMBULANCE		View
	<input type="checkbox"/>	Filler		View
9	<input type="checkbox"/>	OPTLINK		View
10	<input type="checkbox"/>	S-LOCAL		View
	<input type="checkbox"/>	S-LOCAL 2		View
	<input type="checkbox"/>	S-LOCAL 3		View
	<input type="checkbox"/>	S-LOCAL 4		View

Search...	IBC2000.W-PA
BLACKPOOL'S SQUAD WILL BE STRE	5176 17:53:15 12/09/2000 159
(SEE 1100 FRIDAY SEPTEMBER 1 E	5175 17:53:13 12/09/2000 111
PIG FARMERS DEMAND MORE SWINE	5174 17:53:02 12/09/2000 279
BOSTON BOSS STEVE EVANS IS WAI	5173 17:52:52 12/09/2000 115
SCUNTHORPE HAVE NO NEW INJURY	5172 17:52:43 12/09/2000 111
CHESTERFIELD'S UNBEATEN START	5171 17:52:33 12/09/2000 127
ARMY HAILS SUCCESSFUL TRAINING	5170 17:52:25 12/09/2000 563
ARTIST LOSES CANCER BATTLE	5169 17:52:21 12/09/2000 176
(SEE 1100 FRIDAY SEPTEMBER 1 E	5168 17:52:16 12/09/2000 274

The frame-accurate browser can be used to mark in- and out-timecodes, allowing specific portions of clips to be played out under ACC or ACServer control.

3.2.5 Low-res Shot-Selection

Low-resolution material can also be used for simple shot-selection, using the application built into MediaStation, illustrated below.

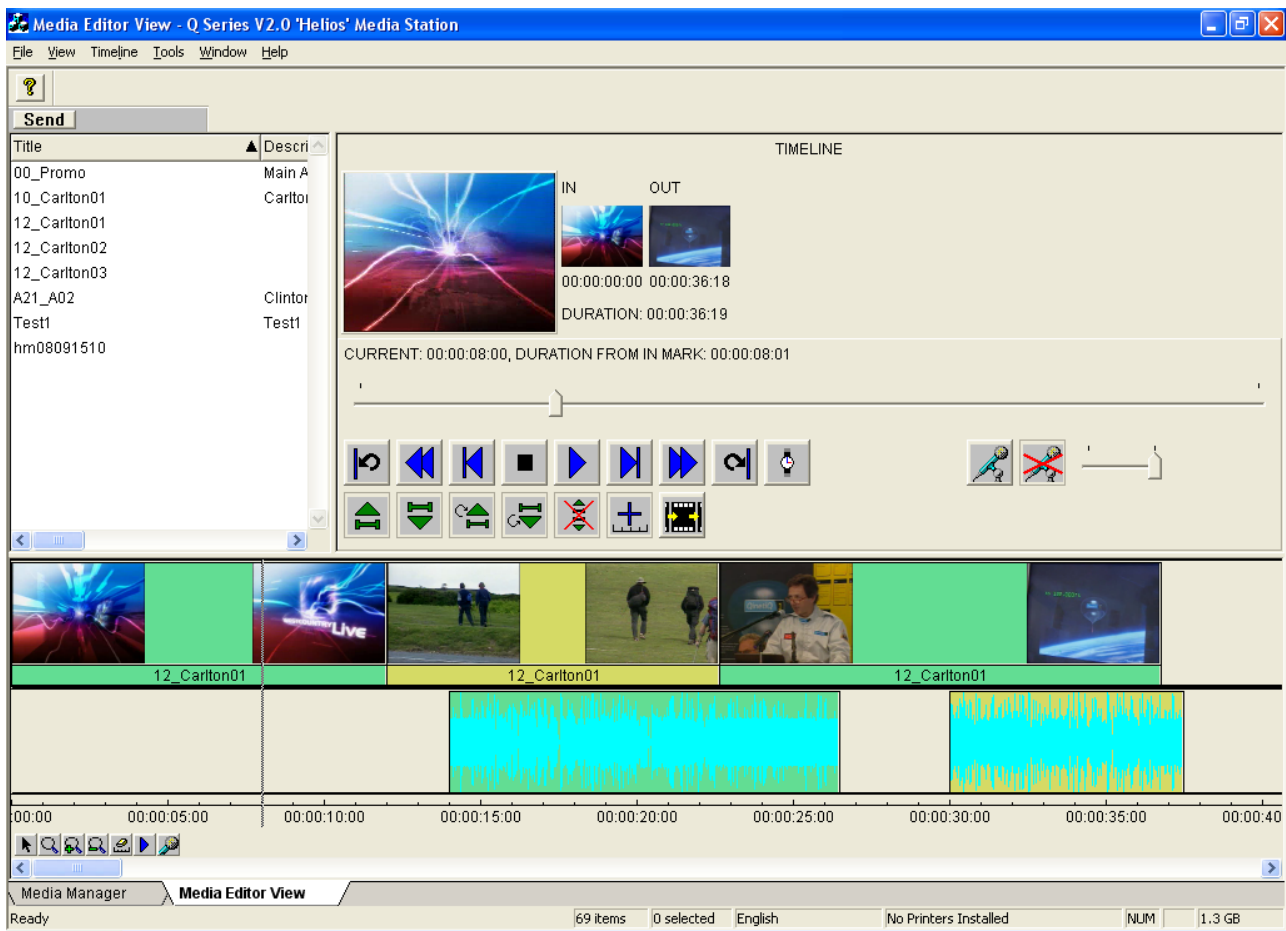

The Shot Selector allows individual low-resolution items to be selected, marked with in- and out-points and dropped onto a timeline. The application is intended as a simple tool to prepare headline sequences or to carry out simple off-line edits prior to starting a craft edit session on a fully functional editor, and as such, video and both channels of audio cut at the same point on the timeline. No other types of transition are possible. The application also provides simple tools to record voice-overs, and position them as required on the timeline, although the ultimate handling of these audio elements is dependent upon the capabilities of the high-resolution server to be used.

There are two options for the 'output' of the QMedia Shot Selector utility; a) a simple EDL file in a specified format to be used by a separate craft editor, or b) the automatic conform of a new clip on high-resolution servers that provide that functionality (including Leitch, Quantel and Omneon devices).

Option a) would be appropriate in the situation where the Shot Selector is used as the tool to choose appropriate material and to construct a rough timeline for finishing (e.g. audio level handling, voice-over and transitions) on a separate craft editor. The EDL generated by the shot selector would be loaded by the craft editor and used to define the starting point for the final edit. This option may require development in order to ensure that the EDL is produced in the correct format required by the particular craft editor in use.

Option b) can conform a brand new high-resolution video clip based on simple cuts-only edit decisions made by users of the low-res Shot Selector. This capability is dependent upon the ability of the video server to use the information contained with an EDL to create a new video clip.

3.3 Playout

Section 3.1 above describes the process of entering CG or video clip information into the scripts and rundown within the QNews client application. These automation events will be available for playout via the QSeries Automation Control Centre (ACC). The ACC provides the user interface for playout control. An example of the ACC screen layout is shown below, although the exact display for any ACC session is flexible, according to user preference.

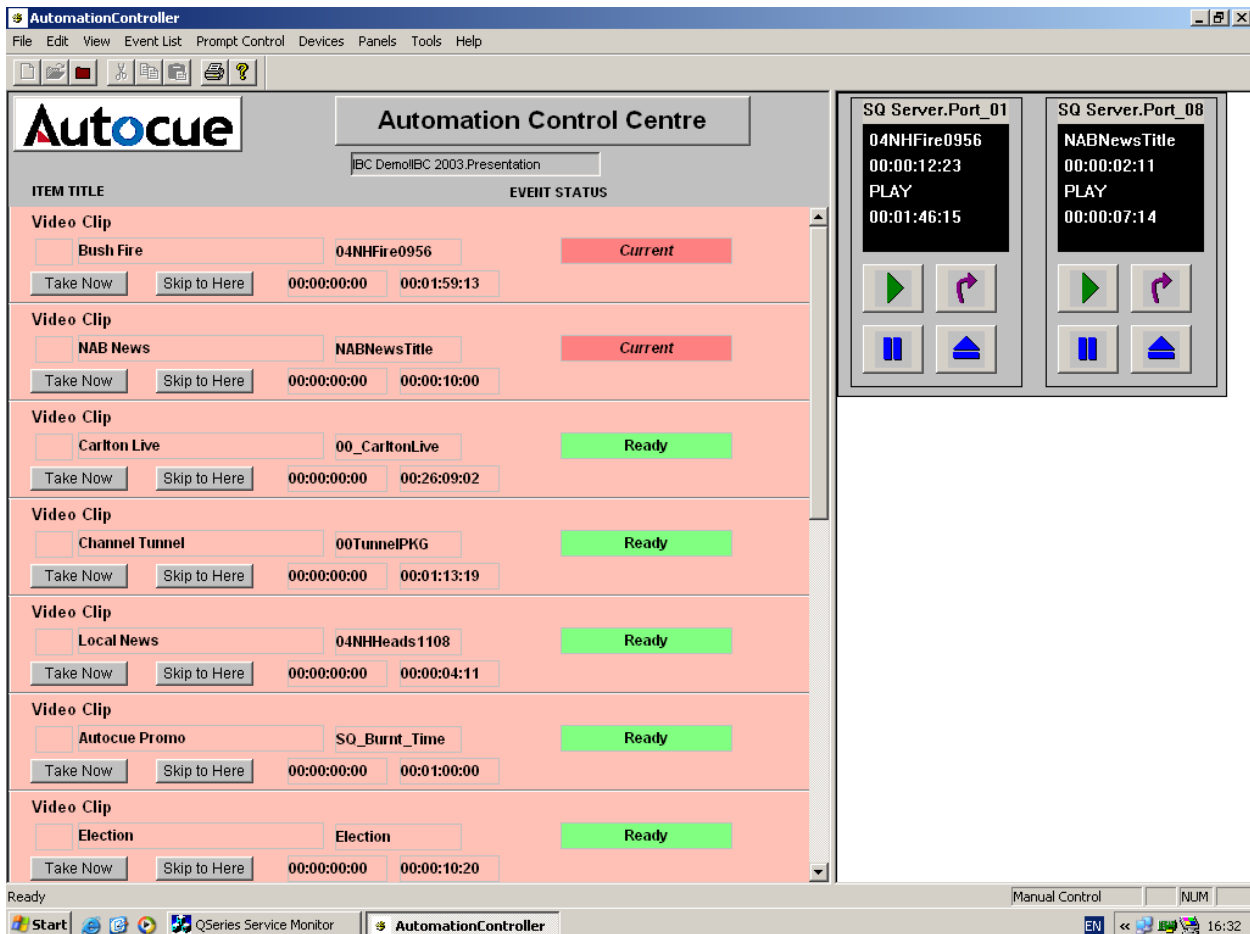

The ACC is divided into two vertical panes; the automation event list and the device control panels.

The left-hand side of the ACC screen shows the automation event list, which will contain one or more different types of events – e.g. video clips and captions. The event list is dynamic, which means that it will immediately reflect any changes to the overall running order, or any change to any particular event. The types of events that appear in the list are defined by the types of devices that are currently being controlled, which is dependent upon the automation profile that the user selected at the start of the ACC session. The profiles are setup according to the overall system configuration and can be used to define, for instance, which server channels are to be used by a particular programme stream. It is possible for a single ACC session to control all the devices required for the current running order, but it is also possible for multiple ACC sessions to each control a single device, all running from the same running order.

The right-hand side of the ACC provides control over the currently connected devices. The control panels vary for different devices, but for a video server channel, for instance, will provide play, pause, recue and skip controls, and status information showing clip name, time code and countdown to the end of the item.

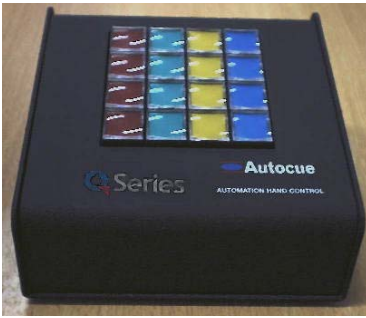

The overall function of the ACC is prepare events (in terms of cueing a tape, loading a video clip or preparing a caption, for instance), but ultimately the point at which an event starts is controlled by an operator – either by clicking one of the on-screen buttons, or from an external button box, connected to the RS232 serial port of the local PC. Four-, twelve- and sixteen-button versions (shown left) are available.

The ACC does not have a direct connection to the devices it is controlling, rather it communicates across the network to the DCI (Device Control Interface) Server. The DCI Server has direct (via serial) and/or indirect (via IP) connections to each controlled device, and translates the generic QSeries automation commands (e.g. 'load', 'cue', 'play', 'take', etc.) received across the network into the specific protocol required by the connected devices. This configuration means that an ACC session, as a purely software component, can be run on any PC on the network.

3.3.1 Mirrored playout

Mirrored playout functionality is available as an option, which means that the ACC loads and plays the same clip on two server channels simultaneously. It is expected that both server outputs will be available on the vision mixer (or production switcher) and if there is a problem with the primary server channel, an operator can switch to the corresponding backup channel via the mixer. The mirrored playout functionality cannot automatically detect a problem with the primary channel, nor can it automatically switch to the backup in an emergency.

3.3.2 Playout workflows

This section combines some of the previous descriptions of functionality together into overall workflows for specific functions.

Clip Selection & Playout

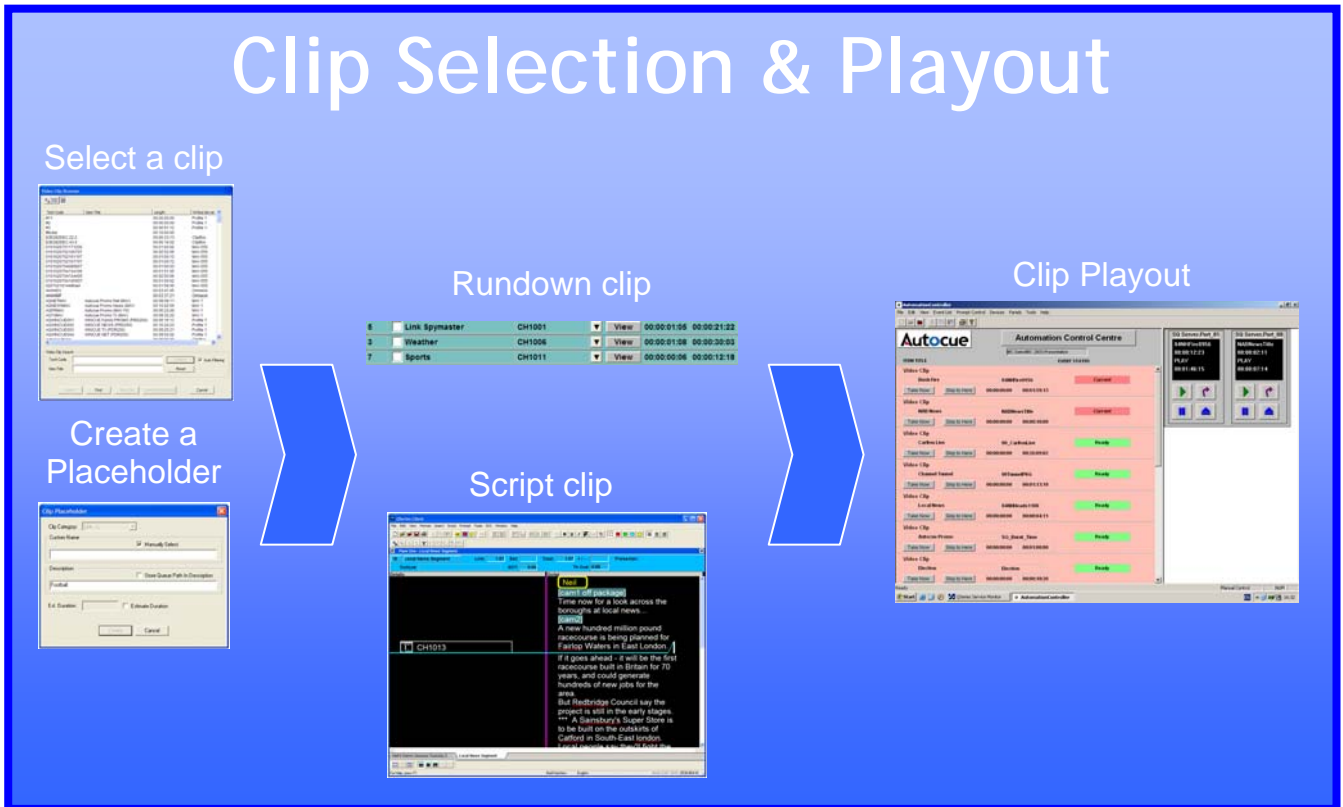

An existing clip can be associated with a rundown item or entered as an event on the left-hand side of a script. Alternatively, for rundown items only, a placeholder can be created to 'reserve' a slot in the video clip database for the new material when it arrives. The list of clips, from both rundown and script levels, are presented as an automation event list in the ACC, including status for each individual clip. The playout of those clips can be controlled manually using device panels that provide control over each channel of the video server.

Clip Ingest

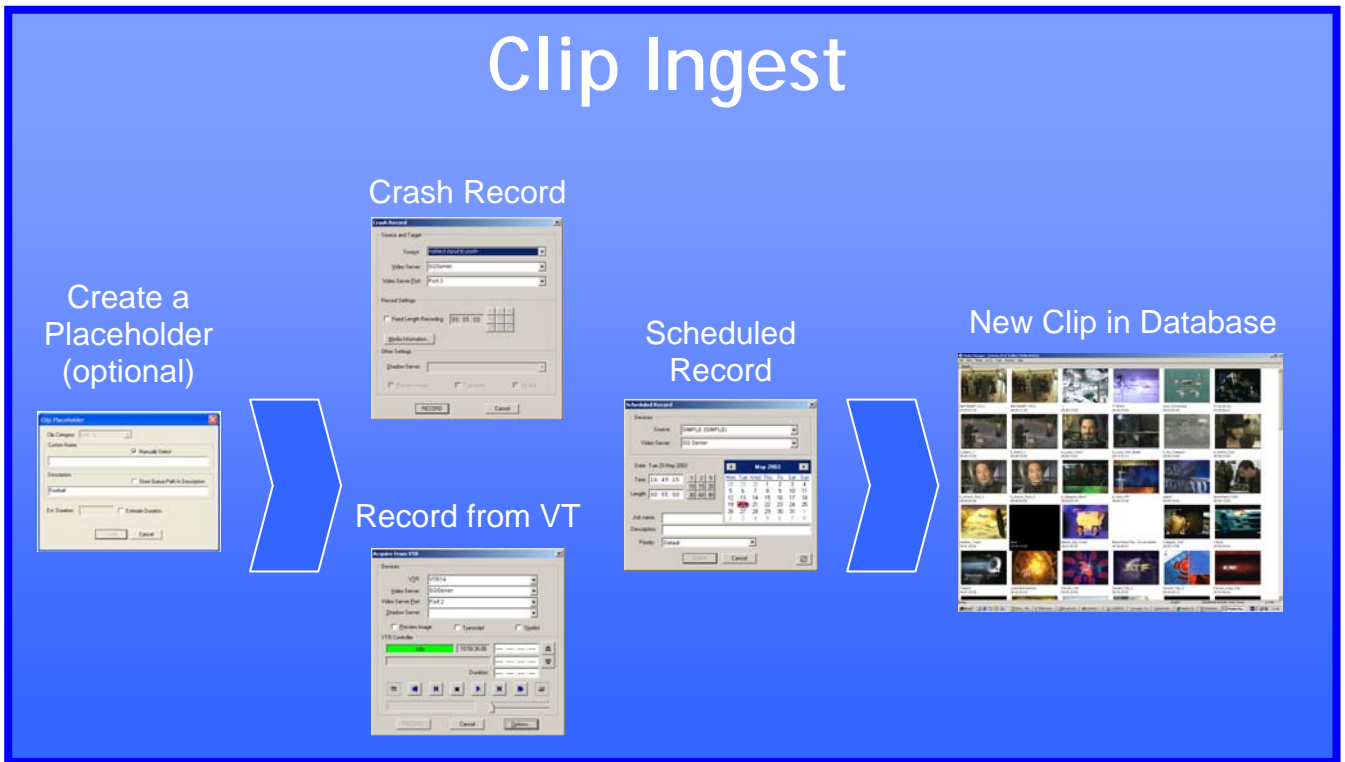

The three ingest methods – crash record, VT record and scheduled record – can record new material into a brand new clip, or make use of an existing placeholder record created from within the QNews NRCS. In either case, once the recording has completed, the new material will be displayed as a clip record within the video clip database, and will be accessible to both newsroom users and technical operators.

CG Selection and Playout



In order to make use of a caption within the QSeries, an appropriate template must exist on the caption generator device itself. This template defines the location, font, size, style, colour and effect properties of the caption. Also, it is necessary to create a representation of that template within QNews, in order that NRCS users have an accurate indication of the caption style they have chosen.

To use a caption, the journalist simply creates an appropriate CG event on the left-hand side of the script. A list of all captions from the rundown is presented as an automation event list in the ACC, and the playout of those captions can be controlled manually using a device panels that provides control over the third-party CG device.

END OF DOCUMENT